

STATE OF MISSOURI  
**DEPARTMENT OF NATURAL RESOURCES**

MISSOURI CLEAN WATER COMMISSION



**MISSOURI STATE OPERATING PERMIT**

In compliance with the Missouri Clean Water Law (Chapter 644 RSMo, hereinafter, the Law), and the Federal Water Pollution Control Act (Public Law 92-500, 92<sup>nd</sup> Congress) as amended,

Permit No.: MO-0140660

Owner: Hodges Farms & Dredging LLC  
Address: 501 N West Street, Lebo, KS 66856

Continuing Authority: Same as above  
Address: Same as above

Facility Name: Beem Site – Wheatland WWTF Biosolids  
Facility Address: 0.1 miles north of Hwy 54 and County Road 161 intersection, Wheatland, MO 65779

Legal Description: See Page 2  
UTM Coordinates: See Page 2

Receiving Stream: See Page 2  
First Classified Stream and ID: See Page 2  
USGS Basin & Sub-watershed No.: See Page 2

authorizes activities pursuant to the terms and conditions of this permit in accordance with the Missouri Clean Water Law and/or the National Pollutant Discharge Elimination System; it does not apply to other regulated activities.

**FACILITY DESCRIPTION**

This permit only authorizes land application of biosolids from the Wheatland Wastewater Treatment Facility.

See Page 2

December 1, 2024  
Effective Date

November 30, 2029  
Expiration Date

\_\_\_\_\_  
John Hoke, Director, Water Protection Program

## **FACILITY DESCRIPTION (continued):**

### Permitted Feature #001 – Non-POTW – Land application field

Land application of biosolids onto agricultural land for beneficial use as a soil amendment

Design Application Flow Rate is ~0.75 million gallons per day

Legal Description:	Sec. 23 and Sec. 24, T37N, R23W, Hickory County
UTM Coordinates:	X=462773, Y=4200626
Receiving Stream:	Tributary to Little Pomme de Terre River
First Classified Stream and ID:	Presumed Use Streams (C) (5057)
USGS Basin & Sub-watershed No.:	(10290107-0403)

### Land Application Design Parameters

Biosolids volume per year:	~2,000,000 gallons
Application areas:	~175.3 acres available
Application rates per acre:	Application rate is based on the Plant Available Nitrogen loading rate
Field slopes:	Less than 8 percent
Equipment type:	Biosolids are land applied by no-till injection or are surface applied by tractor and pull bar, followed by harrow
Vegetation:	Grass hay and pasture
Application rate is based on:	Plant Available Nitrogen loading rate

## **A. STANDARD CONDITIONS**

In addition to specified conditions stated herein, this permit is subject to the attached Parts I & III standard conditions dated August 1, 2014, and August 1, 2019, and hereby incorporated as though fully set forth herein. Annual reports required per Standard Conditions Part III Section K shall be submitted via email to the department at [edmr@dnr.mo.gov](mailto:edmr@dnr.mo.gov) by February 19<sup>th</sup> of each year. This supersedes Standard Conditions Part III Section K #4.

## **B. SPECIAL CONDITIONS**

1. Electronic Discharge Monitoring Report (eDMR) Submission System. Per 40 CFR Part 127 National Pollutant Discharge Elimination System (NPDES) Electronic Reporting Rule, reporting of effluent monitoring data and any report required by the permit (unless specifically directed otherwise by the permit) shall be submitted by the permittee via an electronic system to ensure timely, complete, accurate, and nationally consistent set of data about the NPDES program. All reports uploaded into the system shall be reasonably named so they are easily identifiable, such as “WET Test Chronic Outfall 002 Jan 2023,” or “Outfall 004 Daily Data Mar 2025.”
  - (a) eDMR Registration Requirements. The permittee must register with the department’s eDMR system through the Missouri Gateway for Environmental Management (MoGEM) before the first report is due. Registration and other information regarding MoGEM can be found at <https://dnr.mo.gov/data-e-services/missouri-gateway-environmental-management-mogem>. Information about the eDMR system can be found at <https://dnr.mo.gov/water/business-industry-other-entities/reporting/electronic-discharge-monitoring-reporting-system-edmr>. The first user shall register as an Organization Official and the association to the facility must be approved by the department. Regarding Standard Conditions Part I, Section B, #7, the eDMR system is currently the only department approved reporting method for this permit unless a waiver is granted by the department. See paragraph (c) below.
  - (b) Electronic Submissions. To access the eDMR system, use the following link in your web browser: <https://apps5.mo.gov/mogems/welcome.action>. If you experience difficulties with using the eDMR system you may contact [edmr@dnr.mo.gov](mailto:edmr@dnr.mo.gov) or call 855-789-3889 or 573-526-2082 for assistance.
  - (c) Waivers from Electronic Reporting. The permittee must electronically submit compliance monitoring data and reports unless a waiver is granted by the department in compliance with 40 CFR Part 127. The permittee may obtain an electronic reporting waiver by first submitting an eDMR Waiver Request Form: <https://dnr.mo.gov/document-search/electronic-discharge-monitoring-report-waiver-request-form-mo-780-2692>. The department will either approve or deny this electronic reporting waiver request within 120 calendar days.

## **B. SPECIAL CONDITIONS (continued)**

2. The full implementation of this operating permit, which includes implementation of any applicable schedules of compliance, shall constitute compliance with all applicable federal and state statutes and regulations in accordance with §644.051.15 RSMo, and the Clean Water Act (CWA) Section 402(k); however, this permit may be reopened and modified, or alternatively revoked and reissued:
  - (a) To comply with any applicable effluent standard or limitation issued or approved under Sections 301(b)(2)(C) and (D), 304(b)(2), and 307(a)(2) of the CWA, if the effluent standard or limitation so issued or approved:
    - (1) contains different conditions or is otherwise more stringent than any effluent limitation in the permit; or
    - (2) controls any pollutant not limited in the permit.
3. Reporting of Non-Detects:
  - (a) An analysis conducted by the permittee or their contracted laboratory shall be conducted in such a way that the precision and accuracy of the analyzed result can be enumerated.
  - (b) See sufficiently sensitive test method requirements in Standard Conditions Part I, Section A, No. 4 regarding proper testing and method minimum levels used for sample analysis.
  - (c) The permittee shall not report a sample result as “Non-Detect” without also reporting the method minimum level of the test. Reporting as “Non Detect” without also including the method minimum level, will be considered failure to report, which is a violation of this permit.
  - (d) The permittee shall provide the “Non-Detect” sample result using the less than symbol and the method minimum level (e.g., <50 µg/L, if the method minimum level for the parameter is 50 µg/L).
  - (e) Where the permit contains a department determined Minimum Quantification Level (ML) and the permittee is granted authority in the permit to report zero in lieu of the < ML for a specified parameter (conventional, priority pollutants, metals, etc.), then zero (0) is to be reported for that parameter.
  - (f) For the daily maximum, the facility shall report the highest value. If the highest value was a non-detect, use the less than “<” symbol and the laboratory’s highest method minimum level.
  - (g) For reporting an average based on all non-detected values, remove the “<” sign from the values, average the values, and then add the “<” symbol back to the resulting average.
  - (h) For reporting an average based on a mix of detected and non-detected values (not including *E. coli*), assign a value of “0” for all non-detects for that reporting period and report the average of all the results.
  - (i) When *E. coli* is not detected above the method minimum level, the permittee must report the data qualifier signifying less than detection limit for that parameter (e.g., <1 #/100mL, if the method minimum level is 1 #/100mL). For reporting a geometric mean based on a mix of detected and non-detected values, use one-half of the detection limit (instead of zero) for non-detects when calculating geometric means.
  - (j) See the Fact Sheet Appendix - Non-Detect Example Calculations for further guidance.
4. Access to the land application area and any associated wastewater irrigation equipment must be sufficiently restricted or secured to prevent entry by children, livestock, and unauthorized persons as well as to protect the facility from vandalism.
5. Land Application of Biosolids.
  - (a) Operation. Permittee shall conduct land application of biosolids in accordance with all permit conditions including Standard Conditions Part III, 40 CFR 503, the design parameters listed in the Facility Description section of this permit, and with the department approved Biosolids Management Plan. Land application shall occur only during daylight hours.
  - (b) Land Application Site Locations. This permit authorizes land application of biosolids to the sites that have been public noticed and listed in the permit facility description. Additional land application fields including non-owned property can be added through a permit modification.
  - (c) Subsurface Injection Requirement. Subsurface Injection or immediate incorporation after surface application should be considered where feasible and practicable to reduce exposure to wash off by storm water runoff and to retain nutrients in the soil for crop requirements.
  - (a) Land Application Equipment. The land application system shall be operated so as to provide uniform distribution of applied wastes to the entire application site. Land application shall occur only during daylight hours. Equipment, including land application and transportation/pumping equipment, shall be properly operated and maintained and shall be visually checked daily during land application. Irrigation equipment shall be calibrated at least once per calendar year to ensure even distribution of wastewater.
  - (d) Daily Log Sheets. During land application periods, daily log sheets shall be prepared and kept for each application site, showing the daily percent total solids, amount of biosolids applied per acre, the number of acres applied on, the date and time of each application, and the findings of the daily application equipment check. The daily log sheets shall be kept onsite and made available to department personnel upon request.
  - (e) Buffer Zones. The permittee shall comply with the buffer zone requirements found in Standard Conditions Part III Section G – Land Application of Biosolids #6.d.

**B. SPECIAL CONDITIONS (continued)**

- (f) Slope and Runoff Restrictions.
- (1) Biosolids shall not be land applied in an area that it is reasonably certain that pollutants will be transported into waters of the state, including during storm water runoff.
  - (2) Subsurface injection should be applied along the contour of the slope to minimize surfacing of liquids at the down gradient end of the injection trench.
  - (3) The permittee shall comply with the slope limitations found in Standard Conditions Part III Section G – Land Application of Biosolids #6.e.
- (g) Harvesting, Grazing, and Access. The permittee shall comply with the following harvesting, grazing, and access restrictions:
- (1) Food Crops (human consumption) where the harvested parts are totally above the land surface and do not touch the sludge soil mixture:
    - Food Crops shall not be harvested for 30 days after application of sewage sludge.
  - (2) Food Crops (human consumption) where the harvested parts touch the sludge soil mixture.
    - Food Crops shall not be harvested for 14 months after application.
  - (3) Food Crops (human consumption) with harvested parts below the surface of the land.
    - Food Crops shall not be harvested for 20 months after application if biosolids remain on the land surface for four (4) months or longer before it is incorporated in the ground.
    - Food Crops shall not be harvested for 38 months after application if biosolids remain on the land surface for less than four (4) months before it is incorporated in the ground.
  - (4) Feed Crop (animal consumption) and Fiber Crops:
    - Feed and Fiber Crops shall not be harvested for 30 days after application of sewage sludge.
  - (5) Animal grazing:
    - Animals shall not be grazed on the land for 30 days after application of sewage sludge.
  - (6) Turf:
    - Turf grown on land where sewage sludge is applied shall not be harvested for one year after application of the sewage sludge when the harvested turf is placed on either land with a high potential for public exposure or a lawn.
  - (7) Public Access areas:
    - Public access to land with a high potential for public exposure (including but not limited to public parks, ball fields, cemeteries, nurseries, turf farms, or golf courses) shall be restricted for one year after application of sewage sludge.
    - Public access to land with a low potential for public exposure (including but not limited to rural land application or reclamation sites) shall be restricted for 30 days after application of sewage sludge.
6. Land Application Field Minimum Requirements
- (a) Land application shall not occur when the soil or ground is frosted, frozen, snow covered, or saturated. Saturated soil will hold the shape of any object when pressure is applied (i.e., boot prints). Daily observation of the field is required during land application activities. Application activities shall cease if these conditions occur.
  - (b) Land application shall not occur during a precipitation event or if a precipitation event of 50% chance is forecasted to occur within 24 hours of a planned application. Additionally, plan accordingly for any forecast for a storm or significant rain event. Runoff is always prohibited.
7. The permittee shall comply with the pollutant limitations, monitoring, and other requirements for metals, pathogens, and vectors prior to land application, in accordance with Standard Conditions Part III and 40 CFR Part 503.
8. The following record keeping shall occur:
- (a) Daily land application log showing, at a minimum: daily land application equipment check, date of application, start time of application, volume applied, time forecast was checked, current and next day percent chance of precipitation, time of ending land application, map of portion of field used, and post-application field assessments,
  - (b) Biosolids transportation/pumping and land application equipment inspections,
  - (c) Land application equipment calibration records.
  - (d) Permitted land application field inspection, including runoff, saturation, and ponding,
  - (e) Record of maintenance and repairs for the land application equipment,
  - (f) Dates of when forage harvesting takes place at the land application field or animals are allowed access to the land application field for grazing,
  - (g) Description of any unusual operating conditions encountered, narrative summary of any problems or deficiencies identified, corrective action taken, or improvements planned,
  - (h) Biosolids and soil samples results,
  - (i) Annual summary for the land application field showing number of days application occurred, crop grown and yield data if available, and total amount of biosolids applied (gallons and/or tons per acre), and
  - (j) A record of the agronomic rate calculation for each material applied (document actual sampling results and agronomic rate calculations based on field usage).

**B. SPECIAL CONDITIONS (continued)**

Records shall be maintained for at least five years and be made available to the department upon request.

9. Annual Report. An annual biosolids report shall be submitted by **February 19<sup>th</sup>** of each year. The report shall be emailed to [edmr@dnr.mo.gov](mailto:edmr@dnr.mo.gov) until online submittal is available. When an electronic reporting system compliant with 40 CFR Part 127, the National Pollutant Discharge Elimination System (NPDES) Electronic Reporting Rule, is available, all annual reports must be reported electronically via the new system. In addition to the annual report requirements in Standard Conditions Part III, the annual report shall also include the following:
  - (a) Records required by Special Condition #8 above.
  
10. Renewal Application Requirements.
  - (a) This facility shall submit an appropriate and complete application to the department no less than 180 days prior to the expiration date listed on Page 1 of the permit.
  - (b) Application materials shall include a completed Form B2 and Form I, unless an application form dedicated to land application of biosolids is developed prior to next permit renewal. If a dedicated form is developed, that form shall be used to apply for renewal.

**C. NOTICE OF RIGHT TO APPEAL**

If you were adversely affected by this decision, you may be entitled to pursue an appeal before the administrative hearing commission (AHC) pursuant to §621.250 and §644.051.12 RSMo. To appeal, you must file a petition with the AHC within thirty days after the date this decision was mailed or the date it was delivered, whichever date was earlier. If any such petition is sent by registered mail or certified mail, it will be deemed filed on the date it is mailed; if it is sent by any method other than registered mail or certified mail, it will be deemed filed on the date it is received by the AHC. Any appeal should be directed to:

Administrative Hearing Commission  
U.S. Post Office Building, Third Floor  
131 West High Street, P.O. Box 1557  
Jefferson City, MO 65102-1557  
Phone: 573-751-2422  
Fax: 573-751-5018  
Website: <https://ahc.mo.gov>

**MISSOURI DEPARTMENT OF NATURAL RESOURCES  
FACT SHEET  
FOR THE PURPOSE OF A NEW PERMIT  
MO-0140660  
BEEM SITE - WHEATLAND WWTF BIOSOLIDS**

The Federal Water Pollution Control Act ("Clean Water Act" Section 402 Public Law 92-500 as amended) established the National Pollutant Discharge Elimination System (NPDES) permit program. This program regulates the discharge of pollutants from point sources into the waters of the United States, and the release of stormwater from certain point sources. All such discharges are unlawful without a permit (Section 301 of the "Clean Water Act"). After a permit is obtained, a discharge not in compliance with all permit terms and conditions is unlawful. Missouri State Operating Permits (MSOPs) are issued by the Director of the Missouri Department of Natural Resources (Department) under an approved program, operating in accordance with federal and state laws (Federal "Clean Water Act" and "Missouri Clean Water Law" §644, RSMo, as amended). MSOPs are issued for a period of five (5) years unless otherwise specified.

As per [40 CFR Part 124.8(a)] and [10 CSR 20-6.020(1)(A)2.], a Factsheet shall be prepared to give pertinent information regarding the applicable regulations, rationale for the development of effluent limitations and conditions, and the public participation process for the Missouri State Operating Permit (operating permit) listed below.

A Factsheet is not an enforceable part of an operating permit.

**Part I – Facility Information**

Application Date: 08/14/2024

Facility Type and Description: Non-POTW - Land application field - Land application of biosolids onto agricultural land for beneficial use as a soil amendment

**PERMITTED FEATURE TABLE:**

PERMITTED FEATURE	TREATMENT
#001	Land Application of Biosolids

Comments:

This is a new permit for land application of biosolids from the Wheatland WWTF located in Hickory County.

**Part II – Receiving Stream Information**

While this facility is no discharge, a receiving stream is listed for the purposes of showing what stream would be affected in the event of a discharge.

**PERMITTED FEATURE #001 - RECEIVING STREAM INFORMATION**

**RECEIVING STREAM(S) TABLE:**

WATER-BODY NAME	CLASS	WBID	DESIGNATED USES*	12-DIGIT HUC	DISTANCE TO CLASSIFIED SEGMENT (MI)
Tributary to Little Pomme de Terre River	NA	NA	General Criteria	10290107-0403	1.52
Presumed Use Streams	C	5057	AHP(WWH), WBC-B, SCR, HHP, IRR, LWP		

\*As per 10 CSR 20-7.031 Missouri Water Quality Standards, the department defines the Clean Water Commission's water quality objectives in terms of "water uses to be maintained and the criteria to protect those uses." The receiving stream and 1<sup>st</sup> classified receiving stream's beneficial water uses to be maintained are in the receiving stream table in accordance with [10 CSR 20-7.031(1)(F)].

Uses found in the receiving streams table, above:

10 CSR 20-7.031(1)(F)1.:

**AHP** = Aquatic Habitat Protection - To ensure the protection and propagation of fish, shellfish, and wildlife. AHP is further subcategorized as:

- WWH** = Warm Water Habitat;
- CLH** = Cool Water Habitat;
- CDH** = Cold Water Habitat;
- EAH** = Ephemeral Aquatic Habitat;
- MAH** = Modified Aquatic Habitat;
- LAH** = Limited Aquatic Habitat.

This permit uses Aquatic Life Protection effluent limitations in 10 CSR 20-7.031 Table A for all aquatic habitat designations unless otherwise specified.

10 CSR 20-7.031(1)(F)2.: Recreation in and on the water

**WBC** = Whole Body Contact recreation where the entire body is capable of being submerged. WBC is further subcategorized as:

- WBC-A** = Whole body contact recreation that supports swimming uses and has public access;
- WBC-B** = Whole body contact recreation that supports swimming;

**SCR** = Secondary Contact Recreation (like fishing, wading, and boating).

10 CSR 20-7.031(1)(F)3. to 7.:

- HHP** = Human Health Protection as it relates to the consumption of fish;
- IRR** = Irrigation - Application of water to cropland or directly to cultivated plants that may be used for human or livestock consumption;
- LWP** = Livestock and wildlife protection - Maintenance of conditions in waters to support health in livestock and wildlife;
- DWS** = Drinking water supply;
- IND** = Industrial water supply

10 CSR 20-7.031(1)(F)8-11.: Wetlands (10 CSR 20-7.031 Table A currently does not have corresponding habitat use criteria for these defined uses)

- WSA** = Storm- and flood-water storage and attenuation;
- WHP** = Habitat for resident and migratory wildlife species;
- WRC** = Recreational, cultural, educational, scientific, and natural aesthetic values and uses;
- WHC** = Hydrologic cycle maintenance.

10 CSR 20-7.031(6):

**GRW** = Groundwater

**RECEIVING STREAM(S) LOW-FLOW VALUES:**

RECEIVING STREAM	LOW-FLOW VALUES (CFS)		
	1Q10	7Q10	30Q10
Tributary to Little Pomme de Terre River	0	0	0

**MIXING CONSIDERATIONS**

Mixing Zone: Not Allowed [10 CSR 20-7.031(5)(A)4.B.(I)(a)].

Zone of Initial Dilution: Not Allowed [10 CSR 20-7.031(5)(A)4.B.(I)(b)].

Receiving Water Body’s Water Quality

Section 303(d) of the federal Clean Water Act requires that each state identify waters that are not meeting water quality standards and for which adequate water pollution controls have not been required. Water quality standards protect such beneficial uses of water as whole body contact (such as swimming), maintaining fish and other aquatic life, and providing drinking water for people, livestock and wildlife. The 303(d) list helps state and federal agencies keep track of waters that are impaired but not addressed by normal water pollution control programs.

A TMDL is a calculation of the maximum amount of a given pollutant that a body of water can absorb before its water quality is affected. If a water body is determined to be impaired as listed on the 303(d) list, then a watershed management plan will be developed that shall include the TMDL calculation.

- ✓ This facility conducts biosolids land application; therefore, it does not discharge to a 303(d) listed stream or to a stream with an EPA approved TMDL.

## **Part III – Rationale and Derivation of Effluent Limitations & Permit Conditions**

### **ALTERNATIVE EVALUATIONS FOR NEW FACILITIES:**

As per [10 CSR 20-7.015(4)(A)], discharges to losing streams shall be permitted only after other alternatives including land application, discharges to a gaining stream, and connection to a regional wastewater treatment facility have been evaluated and determined to be unacceptable for environmental and/or economic reasons.

- ✓ The facility does not discharge to a Losing Stream as defined by [10 CSR 20-2.010(40)] & [10 CSR 20-7.031(1)(O)].

### **ANTI-BACKSLIDING:**

A provision in the Federal Regulations [CWA §303(d)(4); CWA §402(o); 40 CFR Part 122.44(l)] that requires a reissued permit to be as stringent as the previous permit with some exceptions.

- ✓ This is a new facility; therefore, backsliding does not apply.

### **ANTIDEGRADATION:**

In accordance with Missouri's Water Quality Standard [10 CSR 20-7.031(3)], for domestic wastewater discharge with new, altered, or expanding discharges, the department is to document by means of Antidegradation Review that the use of a water body's available assimilative capacity is justified. In accordance with Missouri's water quality regulations for antidegradation [10 CSR 20-7.031(3)], degradation may be justified by documenting the socio-economic importance of a discharge after determining the necessity of the discharge. Facilities must submit the antidegradation review request to the department prior to establishing, altering, or expanding discharges. See <https://dnr.mo.gov/document-search/antidegradation-implementation-procedure>.

- ✓ No degradation was proposed in this permit action and no further review necessary. Facility did not apply for authorization to increase pollutant loading or to add additional pollutants to their discharge.

### **AREA-WIDE WASTE TREATMENT MANAGEMENT & CONTINUING AUTHORITY:**

As per [10 CSR 20-6.010(2)(C)], an applicant may utilize a lower preference continuing authority when a higher level authority is available by submitting information as part of the application to the department for review and approval, provided it does not conflict with any area-wide management plan approved under Section 208 of the Federal Clean Water Act or any other regional sewage service and treatment plan approved for higher preference authority by the department.

### **BIOSOLIDS & SEWAGE SLUDGE:**

Biosolids are solid materials resulting from domestic wastewater treatment that meet federal and state criteria for beneficial uses (i.e. fertilizer). Sewage sludge is solids, semi-solids, or liquid residue generated during the treatment of domestic sewage in a treatment works; including but not limited to, domestic septage; scum or solids removed in primary, secondary, or advanced wastewater treatment process; and a material derived from sewage sludge. Sewage sludge does not include ash generated during the firing of sewage sludge in a sewage sludge incinerator or grit and screening generated during preliminary treatment of domestic sewage in a treatment works.

- ✓ Permittee is authorized to land apply biosolids in accordance with Standard Conditions III and 40 CFR 503.

### **COMPLIANCE AND ENFORCEMENT:**

Enforcement is the action taken by the Water Protection Program (WPP) to bring an entity into compliance with the Missouri Clean Water Law, its implementing regulations, and/or any terms and conditions of an operating permit. The primary purpose of the enforcement activity in the WPP is to resolve violations and return the entity to compliance.

### **Facility Performance History:**

- ✓ The facility is not currently under Water Protection Program enforcement action.

### **CONTINUING AUTHORITY:**

Each application for an operating permit shall identify the person, as that term is defined in §644.016(19) RSMo, that is the owner of, operator of, or area-wide management authority for a water contaminant source, point source, wastewater treatment facility, or sewer collection system. This person shall be designated as the continuing authority and shall sign the application. By doing so, the person designated as the continuing authority acknowledges responsibility for compliance with all permit conditions.

10 CSR 20-6.010(2) establishes preferential levels for continuing authorities: Levels 1 through 5 (with Level 1 as the highest level), and generally requires permits to be issued to a higher preference continuing authority if available. A Level 3, 4, or 5 applicant may constitute a continuing authority by showing that Level 1 and Level 2 authorities are not available; do not have jurisdiction; are forbidden by state statute or local ordinance from providing service to the person; or that the Level 3, 4, or 5 applicant has met one of



the requirements listed in paragraphs (2)(C)1.–7. of 10 CSR 20-6.010(2). The seven options in paragraphs (2)(C)1.–7. for a lower-level authority to demonstrate that it is the valid continuing authority are:

1. A waiver from the existing higher authority declining the offer to accept management of the additional wastewater or stormwater;
2. A written statement or a demonstration of non-response from the higher authority;
3. A to-scale map showing all parts of the legal boundary of the facility’s property are beyond 2000 feet from the collection (sewer) system operated by the higher preference authority;
4. A proposed connection or adoption charge by the higher authority that would equal or exceed what is economically feasible for the applicant, which may be in the range of one hundred twenty percent (120%) of the applicant’s cost for constructing or operating a wastewater treatment system;
5. A proposed service fee on the users of the system by the higher authority that is above what is affordable for existing homeowners in that area;
6. Terms for connection or adoption by the higher authority that would require more than two (2) years to achieve full sewer service; or
7. A demonstration that the terms for connection or adoption by the higher authority are not viable or feasible to homeowners in the area.

Permit applicants that are Levels 3, 4, and 5 must, as part of their application, identify their method of compliance with this regulation. The following are the methods to comply.

- No higher level authorities are available to the facility;
- No higher level authorities have jurisdiction;
- Higher level authorities are forbidden by state statute or local ordinance from providing service to the person;
- The existing higher level authority is available to the facility, however the facility has proposed the use of a lower preference continuing authority and has submitted one of the following as part of their application provided it does not conflict with any area-wide management plan approved under Section 208 of the Clean Water Act or by the Missouri Clean Water Commission. (See Fact Sheet Appendix - Continuing Authority for more information on these options):
  - A waiver from the existing higher authority;
  - A written statement or a demonstration of non-response from the higher authority;
  - A to-scale map showing all parts of the legal boundary of the facility’s property are beyond 2000 feet from the collection (sewer) system operated by the higher preference authority;
  - Documentation that the proposed connection or adoption charge by the higher authority would equal or exceed what is economically feasible for the applicant, which may be in the range of one hundred twenty percent (120%) of the applicant’s cost for constructing or operating a wastewater treatment system;
  - Documentation that the proposed service fee on the users of the system by the higher authority is above what is affordable for existing homeowners in that area;
  - Documentation that the terms for connection or adoption by the higher authority would require more than two (2) years to achieve full sewer service;
  - A demonstration that the terms for connection or adoption by the higher authority are not viable or feasible to homeowners in the area;
- ✓ The continuing authority listed on the application is a person. The continuing authority listed on the application form is for a business entity which is incorporated under the laws of Missouri. The business entity is registered with the Missouri Secretary of State’s office and is assigned Charter Number FL0046692 per the Secretary of State’s webpage. The corporation name with that charter number was verified by the permit writer to match the corporation name on the application form. The corporation has a status of “Active” on the Secretary of State’s webpage at the time of the drafting of this permit, and therefore a Level 4 Authority. There is no approved Clean Water Act Section 208 plan in Hickory County. The applicant has shown that:
  - A higher level authority is not available.

**ELECTRONIC DISCHARGE MONITORING REPORT (EDMR) SUBMISSION SYSTEM:**

The U.S. Environmental Protection Agency (EPA) promulgated a final rule on October 22, 2015, to modernize Clean Water Act reporting for municipalities, industries, and other facilities by converting to an electronic data reporting system. This final rule requires regulated entities and state and federal regulators to use information technology to electronically report data required by the National Pollutant Discharge Elimination System (NPDES) permit program instead of filing paper reports. To comply with the federal rule, the department is requiring all permittees to begin submitting discharge monitoring data and reports online. In an effort to aid facilities in the reporting of applicable information electronically, the department has created several new forms including operational control monitoring forms and an I&I location and reduction form. These forms are optional and can be provided upon request to the department.

Per 40 CFR 127.15 and 127.24, permitted facilities may request a temporary waiver for up to 5 years or a permanent waiver from electronic reporting from the department. To obtain an electronic reporting waiver, a permittee must first submit an eDMR Waiver Request Form: <https://dnr.mo.gov/document-search/electronic-discharge-monitoring-report-waiver-request-form-mo-780-2692>. Each facility must make a request. If a single entity owns or operates more than one facility, then the entity must submit a separate request for each facility based on its specific circumstances. An approved waiver is non-transferable.

The department must review and notify the facility within 120 calendar days of receipt if the waiver request has been approved or rejected [40 CFR 124.27(a)]. During the department review period as well as after a waiver is granted, the facility must continue submitting a hard-copy of any reports required by their permit. The department will enter data submitted in hard-copy from those facilities allowed to do so and electronically submit the data to the EPA on behalf of the facility.

- ✓ The permittee is not currently required to use the eDMR data reporting system.

**FEES:**

It is a violation of the Missouri Clean Water Law to fail to pay fees associated with this permit (644.055 RSMo).

**NUMERIC LAKE NUTRIENT CRITERIA:**

- ✓ This facility does not discharge into a lake watershed where numeric lake nutrient criteria are applicable.

**OPERATOR CERTIFICATION REQUIREMENTS:**

As per [10 CSR 20-6.010(8) Terms and Conditions of a Permit], the permittee shall operate and maintain facilities to comply with the Missouri Clean Water Law and applicable permit conditions and regulations. Operators at regulated wastewater treatment facilities shall be certified in accordance with [10 CSR 20-9.020(2)] and any other applicable state law or regulation. As per [10 CSR 20-9.020(2)(A)], requirements for operation by certified personnel shall apply to all wastewater treatment systems with population equivalents greater than 200 and are owned or operated by or for municipalities, public sewer districts, counties, public water supply districts, private sewer companies regulated by the Public Service Commission and state or federal agencies.

- ✓ This facility is not required to have a certified operator as it doesn't have a PE greater than 200 and/or is not owned or operated by or for a municipality, public sewer district, county, public water supply district, private sewer company regulated by the PSC, state or federal agency.

**OPERATIONAL CONTROL TESTING:**

Missouri Clean Water Commission regulation 10 CSR 20-9.010 requires certain publicly owned treatment works and privately owned facilities regulated by the Public Service Commission to conduct internal operational control monitoring to further ensure proper operation of the facility and to be a safeguard or early warning for potential plant upsets that could affect effluent quality. This requirement is only applicable if the publicly owned treatment works and privately owned facilities regulated by the Public Service Commission has a calculated Population Equivalent greater than two hundred (200).

10 CSR 20-9.010(3) allows the department to modify the monitoring frequency required in the rule based upon the department's judgement of monitoring needs for process control at the specified facility.

- ✓ As per [10 CSR 20-9.010(4)], the facility is not required to conduct operational monitoring.

**VARIANCE:**

As per §644.061.4 RSMo, variances shall be granted for such period of time and under such terms and conditions as shall be specified by the commission in its order. The variance may be extended by affirmative action of the commission. In no event shall the variance be granted for a period of time greater than is reasonably necessary for complying with the Missouri Clean Water Law §644.006 to §644.141 RSMo, or any standard, rule or regulation promulgated pursuant to §644.006 to §644.141 RSMo.

- ✓ This operating permit is not drafted under premises of a petition for variance.

**WASTELOAD ALLOCATIONS (WLA) FOR LIMITS:**

As per [10 CSR 20-2.010(86)], the amount of pollutant each discharger is allowed by the department to release into a given stream after the department has determined total amount of pollutant that may be discharged into that stream without endangering its water quality.

- ✓ Wasteload allocations were not calculated.

**WLA MODELING:**

There are two general types of effluent limitations, technology-based effluent limits (TBELs) and water quality-based effluent limits (WQBELs). If TBELs do not provide adequate protection for the receiving waters, then WQBEL must be used.

- ✓ A WLA study was either not submitted or determined not applicable by department staff.

**Part IV – Cost Analysis for Compliance**

Pursuant to §644.145 RSMo, when issuing permits under this chapter that incorporate a new requirement for discharges from publicly owned combined or separate sanitary or storm sewer systems or publicly owned treatment works, or when enforcing provisions of this chapter or the Federal Water Pollution Control Act, 33 U.S.C. 1251 et seq., pertaining to any portion of a publicly owned combined or separate sanitary or storm sewer system or [publicly owned] treatment works, the Department of Natural Resources shall make a “finding of affordability” on the costs to be incurred and the impact of any rate changes on ratepayers upon which to base such permits and decisions, to the extent allowable under this chapter and the Federal Water Pollution Control Act. This process is completed through a cost analysis for compliance. Permits that do not include new requirements may be deemed affordable.

- ✓ The department is not required to complete a cost analysis for compliance because the facility is not a combined or separate sanitary sewer system for a publicly-owned treatment works.

**Part V – Administrative Requirements**

On the basis of preliminary staff review and the application of applicable standards and regulations, the department, as administrative agent for the Missouri Clean Water Commission, proposes to issue a permit(s) subject to certain effluent limitations, schedules, and special conditions contained herein and within the operating permit. The proposed determinations are tentative pending public comment.

**WATER QUALITY STANDARD REVISION:**

In accordance with §644.058 RSMo, the department is required to utilize an evaluation of the environmental and economic impacts of modifications to water quality standards of twenty-five percent or more when making individual site-specific permit decisions.

- ✓ This operating permit does not contain requirements for a water quality standard that has changed twenty-five percent or more since the previous operating permit.

**PUBLIC NOTICE:**

The department shall give public notice that a draft permit has been prepared and its issuance is pending. Additionally, public notice will be issued if a public hearing is to be held because of a significant degree of interest in and water quality concerns related to a draft permit. No public notice is required when a request for a permit modification or termination is denied; however, the requester and permittee must be notified of the denial in writing. The department must issue public notice of a pending operating permit or of a new or reissued statewide general permit. The public comment period is the length of time not less than 30 days following the date of the public notice which interested persons may submit written comments about the proposed permit. For persons wanting to submit comments regarding this proposed operating permit, then please refer to the Public Notice page located at the front of this draft operating permit. The Public Notice page gives direction on how and where to submit appropriate comments.

- ✓ The Public Notice period for this operating permit was from Oct. 11, 2024, to Nov. 11, 2024. No responses received.

**DATE OF FACT SHEET:** NOVEMBER 12, 2024

**COMPLETED BY:**

**BRANT FARRIS, ENVIRONMENTAL PROGRAM SPECIALIST  
MISSOURI DEPARTMENT OF NATURAL RESOURCES  
WATER PROTECTION PROGRAM  
OPERATING PERMITS SECTION - DOMESTIC WASTEWATER UNIT  
(660) 385-8019  
brant.farris@dnr.mo.gov**

## Appendices

### APPENDIX – Non-Detect Example Calculations:

**Example:** Permittee has four samples for Pollutant X which has a method minimum level of 5 mg/L and is to report a Daily Maximum and Monthly Average.

Week 1 = 11.4 mg/L  
Week 2 = Non-Detect or <5.0 mg/L  
Week 3 = 7.1 mg/L  
Week 4 = Non-Detect or <5.0 mg/L

For this example, use subpart (h) - For reporting an average based on a mix of detected and non-detected values (not including *E. coli*), assign a value of “0” for all non-detects for that reporting period and report the average of all the results.

$$11.4 + 0 + 7.1 + 0 = 18.5 \div 4 \text{ (number of samples)} = 4.63 \text{ mg/L.}$$

The Permittee reports a Monthly Average of 4.63 mg/L and a Daily maximum of 11.4 mg/L (Note the < symbol was dropped in the answers).

**Example:** Permittee has five samples for Pollutant Y that has a method minimum level of 9 µg/L and is to report a Daily Maximum and Monthly Average.

Day 1 = Non-Detect or <9.0 µg/L  
Day 2 = Non-Detect or <9.0 µg/L  
Day 3 = Non-Detect or <9.0 µg/L  
Day 4 = Non-Detect or <9.0 µg/L  
Day 5 = Non-Detect or <9.0 µg/L

For this example, use subpart (g) - For reporting an average based on all non-detected values, remove the “<” sign from the values, average the values, and then add the “<” symbol back to the resulting average.

$$(9 + 9 + 9 + 9 + 9) \div 5 \text{ (number of samples)} = <9 \text{ µg/L.}$$

The Permittee reports a Monthly Average of <9.0 µg/L (retain the ‘less than’ symbol) and a Daily Maximum of <9.0 µg/L.

**Example:** Permittee has four samples for Pollutant Z where the first two tests were conducted using a method with a method minimum level of 4 µg/L and the remaining two tests were conducted using a different method that has a method minimum level of <6 µg/L and is to report a Monthly Average and a Weekly Average.

Week 1 = Non-Detect or <4.0 µg/L  
Week 2 = Non-Detect or <4.0 µg/L  
Week 3 = Non-Detect or <6.0 µg/L  
Week 4 = Non-Detect or <6.0 µg/L

For this example, use subpart (g) - For reporting an average based on all non-detected values, remove the “<” sign from the values, average the values, and then add the “<” symbol back to the resulting average.

$$(4 + 4 + 6 + 6) \div 4 \text{ (number of samples)} = <5 \text{ µg/L. (Monthly)}$$

The facility reports a Monthly Average of <5.0 µg/L and a Weekly Average of <6.0 µg/L.

**APPENDIX – Non-Detect Example Calculations (Continued):**

**Example:** Permittee has five samples for Pollutant Z where the first two tests were conducted using a method with a method minimum level of 4 µg/L and the remaining three tests were conducted using a different method that has a method minimum level of <6 µg/L and is to report a Monthly Average and a Weekly Average.

Week 1 = Non-Detect or <4.0 µg/L  
Week 2 = Non-Detect or <4.0 µg/L  
Week 2 = Non-Detect or <6.0 µg/L  
Week 3 = Non-Detect or <6.0 µg/L  
Week 4 = Non-Detect or <6.0 µg/L

For this example, use subpart (g) - For reporting an average based on all non-detected values, remove the “<” sign from the values, average the values, and then add the “<” symbol back to the resulting average.

$$(4 + 4 + 6 + 6 + 6) \div 5 \text{ (number of samples)} = <5.2 \text{ µg/L. (Monthly)}$$
$$(4 + 6) \div 2 \text{ (number of samples)} = <5 \text{ µg/L. (Week 2)}$$

The facility reports a Monthly Average of <5.2 µg/L and a Weekly Average of <6.0 µg/L (report highest Weekly Average value)

**Example:** Permittee has four samples for Pollutant Z where the tests were conducted using a method with a method minimum level of 10 µg/L and is to report a Monthly Average and Daily Maximum. The permit lists that Pollutant Z has a department determined Minimum Quantification Level (ML) of 130 µg/L.

Week 1 = 12 µg/L  
Week 2 = 52 µg/L  
Week 3 = Non-Detect or <10 µg/L  
Week 4 = 133 µg/L

For this example, use subpart (h) - For reporting an average based on a mix of detected and non-detected values (not including *E. coli*), assign a value of “0” for all non-detects for that reporting period and report the average of all the results.

$$\text{For this example, } (12 + 52 + 0 + 133) \div 4 \text{ (number of samples)} = 197 \div 4 = 49.3 \text{ µg/L.}$$

The facility reports a Monthly Average of 49.3 µg/L and a Daily Maximum of 133 µg/L.

**Example:** Permittee has five samples for *E. coli* which has a method minimum level of 1 #/100mL and is to report a Weekly Average (seven (7) day geometric mean) and a Monthly Average (thirty (30) day geometric mean).

Week 1 = 102 #/100mL  
Week 2 (Monday) = 400 #/100mL  
Week 2 (Friday) = Non-Detect or <1 #/100mL  
Week 3 = 15 #/100mL  
Week 4 = Non-Detect or <1 #/100mL

For this example, use subpart (i) - When *E. coli* is not detected above the method minimum level, the permittee must report the data qualifier signifying less than detection limit for that parameter (e.g., <1 #/100mL, if the method minimum level is 1 #/100mL). For reporting a geometric mean based on a mix of detected and non-detected values, use one-half of the detection limit (instead of zero) for non-detects when calculating geometric means. The Geometric Mean is calculated by multiplying all of the data points and then taking the nth root of this product, where n = # of samples collected.

$$\text{The Monthly Average (30 day Geometric Mean)} = 5\text{th root of } (102)(400)(0.5)(15)(0.5) = 5\text{th root of } 153,000 = 10.9 \text{ #/100mL.}$$
$$\text{The 7 day Geometric Mean} = 2\text{nd root of } (400)(0.5) = 2\text{nd root of } 200 = 14.1 \text{ #/100mL. (Week 2)}$$

The Permittee reports a Monthly Average (30 day Geometric Mean) of 10.9 #/100mL and a Weekly Average (7 day geometric mean) of 102 #/100mL (report highest Weekly Average value)

APPENDIX – SITE MAP:

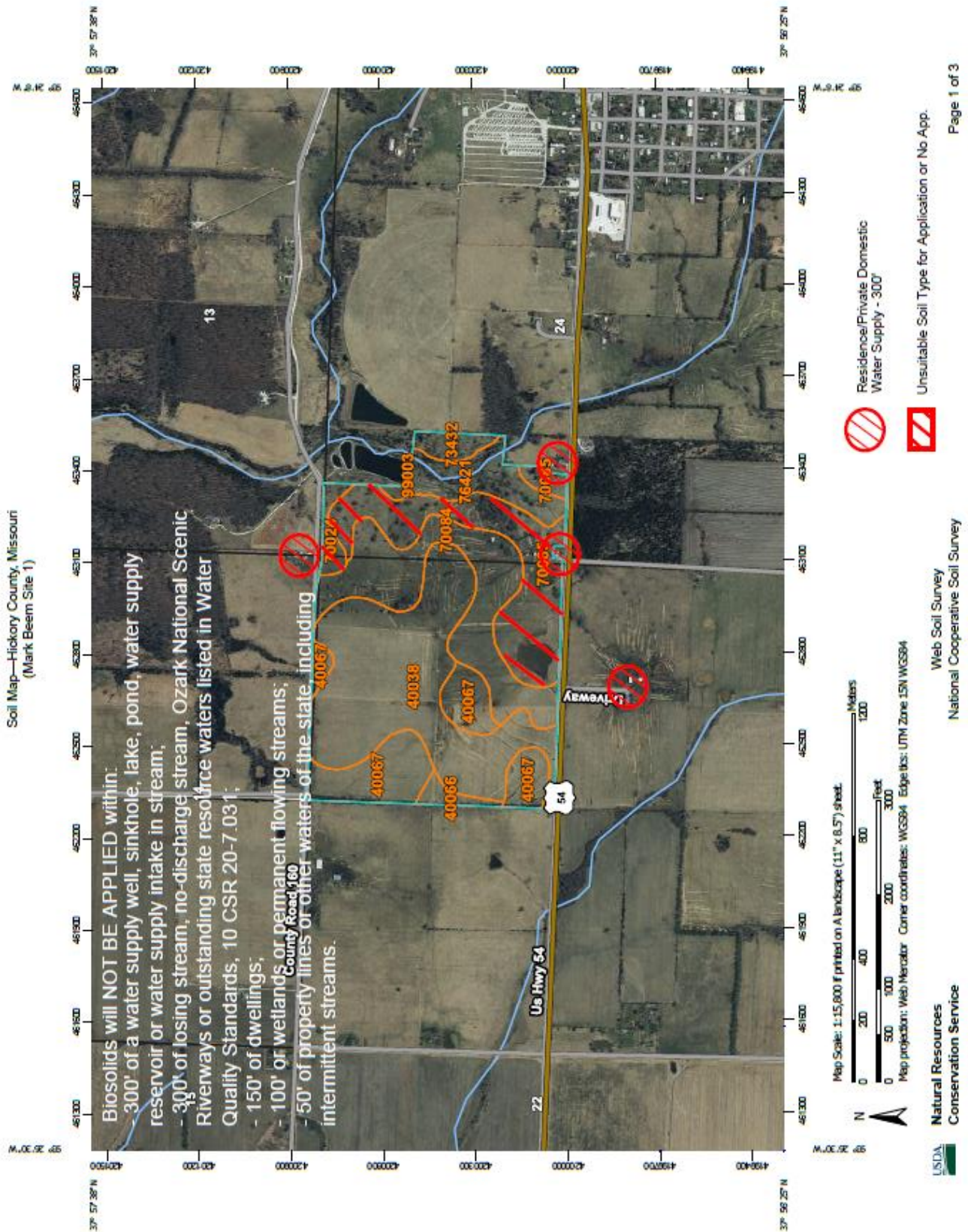



MISSOURI DEPARTMENT OF NATURAL RESOURCES  
WATER PROTECTION PROGRAM

**FORM B: APPLICATION FOR OPERATING PERMIT FOR FACILITIES THAT RECEIVE PRIMARILY DOMESTIC WASTE AND HAVE A DESIGN FLOW LESS THAN OR EQUAL TO 100,000 GALLONS PER DAY**

FOR AGENCY USE ONLY	
CHECK NUMBER	
DATE RECEIVED	FEE SUBMITTED
JETPAY CONFIRMATION NUMBER	

**READ THE ACCOMPANYING INSTRUCTIONS BEFORE COMPLETING THIS FORM**

**1. THIS APPLICATION IS FOR:**

- An operating permit for a new or unpermitted facility. Construction Permit # \_\_\_\_\_  
(Include completed antidegradation review or request for antidegradation review, see instructions)
- A new site-specific operating permit formerly general permit #MOG \_\_\_\_\_
- A site-specific operating permit renewal: Permit #MO- \_\_\_\_\_ Expiration Date \_\_\_\_\_
- A site-specific operating permit modification: Permit #MO- \_\_\_\_\_ Reason: \_\_\_\_\_
- General permit (NON-POTWs) (MOGD –discharging < 50,000 GPD or MOG823 – Land Application of Domestic Wastewater):  
Permit #MO- \_\_\_\_\_ Expiration Date \_\_\_\_\_

**1.1** Is the appropriate fee included with the application (see instructions for appropriate fee)?  YES  NO

**2. FACILITY**

NAME		TELEPHONE NUMBER WITH AREA CODE	
ADDRESS (PHYSICAL)	CITY	STATE	ZIP CODE

**2.1** Legal description: Sec. \_\_\_\_\_, T \_\_\_\_\_, R \_\_\_\_\_ County \_\_\_\_\_

**2.2** UTM Coordinates Easting (X): \_\_\_\_\_ Northing (Y): \_\_\_\_\_  
*For Universal Transverse Mercator (UTM), Zone 15 North referenced to North American Datum 1983 (NAD83)*

**2.3** Name of receiving stream: \_\_\_\_\_

**2.4** Number of outfalls: \_\_\_\_\_ Wastewater outfalls: \_\_\_\_\_ Stormwater outfalls: \_\_\_\_\_ Instream monitoring sites: \_\_\_\_\_

**3. OWNER:**

NAME		EMAIL ADDRESS	TELEPHONE NUMBER WITH AREA CODE
ADDRESS	CITY	STATE	ZIP CODE

**3.1** Request review of draft permit prior to public notice?  YES  NO

**3.2** Are you a publicly owned treatment works?  YES  NO  
**If yes**, please attach the Financial Questionnaire. See: <https://dnr.mo.gov/forms/780-2511-f.pdf>

**3.3** Are you a privately owned treatment works?  YES  NO

**3.4** Are you a privately owned treatment facility regulated by the Public Service Commission?  YES  NO

**4. CONTINUING AUTHORITY:**

NAME		EMAIL ADDRESS	TELEPHONE NUMBER WITH AREA CODE
ADDRESS	CITY	STATE	ZIP CODE

If the continuing authority is different than the owner, include a copy of the contract agreement between the two parties and a description of the responsibilities of both parties within the agreement.

**5. OPERATOR**

NAME	TITLE	CERTIFICATE NUMBER
EMAIL ADDRESS	TELEPHONE NUMBER WITH AREA CODE	

**6. FACILITY CONTACT**

NAME		TITLE	
EMAIL ADDRESS		TELEPHONE NUMBER WITH AREA CODE	
ADDRESS	CITY	STATE	ZIP CODE

## 7. DESCRIPTION OF FACILITY

**7.1 Process Flow Diagram or Schematic:** Provide a diagram showing the processes of the treatment plant. Show all of the treatment units, including disinfection (e.g. – chlorination and dechlorination), influents, and outfalls. Specify where samples are taken. Indicate any treatment process changes in the routing of wastewater during dry weather and peak wet weather. Include a brief narrative description of the diagram.

Attach sheets as necessary.

**7.2** Attach an aerial photograph or USGS topographic map showing the location of the facility and outfall.

Please see the following website:

<https://modnr.maps.arcgis.com/apps/webappviewer/index.html?id=1d81212e0854478ca0dae87c33c8c5ce>



**8. ADDITIONAL FACILITY INFORMATION**

**8.1** Number of people presently connected or population equivalent (P.E.) \_\_\_\_\_ Design P.E. \_\_\_\_\_

**8.2** Connections to the facility:  
 Number of units presently connected:  
 Residential: \_\_\_\_\_ Commercial: \_\_\_\_\_ Industrial: \_\_\_\_\_

**8.3** Design flow: \_\_\_\_\_ Actual flow: \_\_\_\_\_

**8.4** Will discharge be continuous through the year?  Yes  No  
 Discharge will occur during the following months: \_\_\_\_\_  
 How many days of the week will discharge occur? \_\_\_\_\_

**8.5** Is industrial wastewater discharged to the facility?  Yes  No  
**If yes**, attach a list of the industries that discharge to your facility

**8.6** Does the facility accept or process leachate from landfills?  Yes  No

**8.7** Is wastewater land applied?  Yes  No  
**If yes**, attach Form I. See: <https://dnr.mo.gov/forms/780-1686-f.pdf>

**8.8** Does the facility discharge to a losing stream or sinkhole?  Yes  No

**8.9** Has a wasteload allocation study been completed for this facility?  Yes  No

**9. LABORATORY CONTROL INFORMATION**

LABORATORY WORK CONDUCTED BY PLANT PERSONNEL

Lab work conducted outside of plant.  Yes  No

Push-button or visual methods for simple test such as pH, settleable solids.  Yes  No

Additional procedures such as dissolved oxygen, chemical oxygen demand, biological oxygen demand, titrations, solids, volatile content.  Yes  No

More advanced determinations, such as BOD seeding procedures, fecal coliform/*E. coli*, nutrients (including Ammonia), Oil & Grease, \ total oils, phenols, etc.  Yes  No

Highly sophisticated instrumentation, such as atomic absorption and gas chromatograph.  Yes  No

**10. COLLECTION SYSTEM**

**10.1** Are there any municipal satellite collection systems connected to this facility? \_\_\_\_\_ Yes \_\_\_\_\_ No  
 If yes, please list all connected to this facility, contact phone number and length of each collection system

FACILITY NAME	CONTACT PHONE NUMBER	LENGTH OF SYSTEM (FEET OR MILES)

**10.2** Length of pipe in the sewer collection system? (If available, include totals from satellite collection systems)  
 \_\_\_\_\_ Feet, or \_\_\_\_\_ Miles (either unit is appropriate)

**10.3** Does significant infiltration occur in the collection system?  Yes  No  
 If yes, briefly explain any steps underway or planned to minimize inflow and infiltration:

**11. BYPASSING**

Does any bypassing occur in the collection system or at the treatment facility?  Yes  No

If yes, explain:

**12. SLUDGE HANDLING, USE AND DISPOSAL**

**12.1** Is the sludge a hazardous waste as defined by 10 CSR 25?  Yes  No

**12.2** Sludge production, including sludge received from others: \_\_\_\_\_ Design dry tons/year \_\_\_\_\_ Actual dry tons/year

**12.3** Capacity of sludge holding structures:  
 Sludge storage provided: \_\_\_\_\_ cubic feet; \_\_\_\_\_ days of storage; \_\_\_\_\_ average percent solids of sludge;  
 No sludge storage is provided.  Sludge is stored in lagoon.

**12.4** Type of Storage:  Holding tank  Building  
 Basin  Lagoon  
 Concrete Pad  Other (Describe) \_\_\_\_\_

**12.5** Sludge Treatment:  
 Anaerobic Digester  Lagoon  Composting  
 Storage Tank  Aerobic Digester  Other (Attach description)  
 Lime Stabilization  Air or Heat Drying

**12.6** Sludge Use or Disposal:  
 Land Application  Surface Disposal (Sludge Disposal Lagoon, Sludge held for more than two years)  
 Contract Hauler  Hauled to Another treatment facility  
 Incineration  Sludge Retained in Wastewater treatment lagoon  
 Solid waste landfill

**12.7** Person responsible for hauling sludge to disposal facility:  
 By applicant  By others (complete below)

NAME		EMAIL ADDRESS	
ADDRESS	CITY	STATE	ZIP CODE
CONTACT PERSON	TELEPHONE NUMBER WITH AREA CODE	PERMIT NO. MO-	

**12.8** Sludge use or disposal facility  
 By applicant  By others (Complete below.)

NAME		EMAIL ADDRESS	
ADDRESS	CITY	STATE	ZIP CODE
CONTACT PERSON	TELEPHONE NUMBER WITH AREA CODE	PERMIT NO. MO-	

**12.9** Does the sludge or biosolids disposal comply with federal sludge regulations under 40 CFR 503?  
 Yes  No (Explain)

**13. ELECTRONIC DISCHARGE MONITORING REPORT (eDMR) SUBMISSION SYSTEM**

Per 40 CFR Part 127, National Pollutant Discharge Elimination System (NPDES) Electronic Reporting Rule, reporting of effluent limits and monitoring shall be submitted by the permittee via an electronic system to ensure a timely, complete, accurate, and nationally- consistent set of data. One of the following options must be checked in order for this application to be considered complete. Visit <https://dnr.mo.gov/env/wpp/edmr.htm> to for information on the Department's eDMR system and how to register.

- I will register an account online to participate in the Department's eDMR system through the Missouri Gateway for Environmental Management (MoGEM) before any reporting is due, in compliance with the Electronic Reporting Rule.
- I have already registered an account online to participate in the Department's eDMR system through MoGEM.
- I have submitted a written request for a waiver from electronic reporting. See instructions for further information regarding waivers.
- The permit I am applying for does not require the submission of discharge monitoring reports.

**14. JETPAY**

Permit fees may be paid online by credit card or eCheck through a system called JetPay. Use the URL provided to access JetPay and make an online payment.

New Site Specific Permit: <https://magic.collectorsolutions.com/magic-ui/payments/mo-natural-resources/591/>

Construction Permits: <https://magic.collectorsolutions.com/magic-ui/payments/mo-natural-resources/592/>

Modification Fee: <https://magic.collectorsolutions.com/magic-ui/payments/mo-natural-resources/596/>

New General Domestic WW: <https://magic.collectorsolutions.com/magic-ui/payments/mo-natural-resources/772/>

**15. CERTIFICATION**

I certify under penalty of law that this document and all attachments were prepared under my direction or supervision in accordance with a system designed to assure that qualified personnel properly gather and evaluate the information submitted. Based on my inquiry of the person or persons who manage the system, or those persons directly responsible for gathering the information, the information submitted is, to the best of my knowledge and belief, true, accurate, and complete. I am aware that there are significant penalties for submitting false information, including the possibility of fine and imprisonment for knowing violations.

NAME (TYPE OR PRINT)	OFFICIAL TITLE	TELEPHONE NUMBER WITH AREA CODE
SIGNATURE 		DATE SIGNED

**INSTRUCTIONS FOR COMPLETING FORM B: APPLICATION FOR OPERATING PERMIT FOR FACILITIES THAT RECEIVE PRIMARILY DOMESTIC WASTE AND HAVE A DESIGN FLOW LESS THAN OR EQUAL TO 100,000 GALLONS PER DAY**  
**(Facilities over 100,000 gallons per day of domestic waste must use FORM B2)**  
**(Facilities that receive wastes other than domestic contact the department)**

1. Check the appropriate box. **Do not check more than one item.** Operating permit refers to a permit issued by the Department of Natural Resources' Water Protection Program. If an Antidegradation Review has not been conducted, submit the application located at the following link to the Missouri Department of Natural Resources, Water Protection Program, P.O. Box 176, Jefferson City, MO 65102: [dnr.mo.gov/forms/780-1893-f.pdf](http://dnr.mo.gov/forms/780-1893-f.pdf).

1.1 **Fees Information:**

**DOMESTIC OPERATING PERMIT FEES – PRIVATE**

Annual operating permit fees are based on flow.

Annual fee/Design flow	Annual fee/Design flow	Annual fee/Design flow
\$150.....<5,000 gpd	\$1,000.....15,000-24,999 gpd	\$4,000.....100,000-249,999 gpd
\$300.....5,000-9,999 gpd	\$1,500.....25,000-29,999 gpd	\$5,000.....≥250,000 gpd
\$600.....10,000-14,999 gpd	\$3,000.....30,000-99,999 gpd	

New domestic wastewater treatment facilities must submit the annual fee with the original application.

**If the application is for a site-specific permit re-issuance, send no fees.** You will be invoiced separately by the department on the anniversary date of the original permit. Permit fees must be current for the department to reissue the operating permit. Late fees of 2% per month are charged and added to outstanding annual fees.

**PUBLIC SEWER SYSTEM OPERATING PERMIT FEES** (city, public sewer district, public water district, or other publicly owned treatment works that charge a service connection fee). Annual fee is based on number of service connections. Fees listings are found in 10 CSR 20-6.011 which is available at <http://s1.sos.mo.gov/cmsimages/adrules/csr/current/10csr/10c20-6.pdf>. New public sewer system facilities should not submit any fee as the department will invoice the permittee.

**OPERATING PERMIT MODIFICATIONS**, including transfers, are subject to the following fees:

- a. Operating permits that charge a service connection fee - \$200 each.
- b. All other permits
  - (1) \$100 each for a minor modification (name changes, address changes, other non-substantive changes) or
  - (2) A fee equal to 25% of the facility's annual operating fee for a major modification.

2. Name of Facility – Include the name by which this facility is locally known. Example: Southwest Sewage Treatment Plant, Country Club Mobile Home Park, etc. Provide the street address or location of the facility. If the facility lacks a street name or route number, provide the names of the closest intersection, highway, country road, etc.

2.1 Self-explanatory

2.2 Global Positioning System, or GPS, is a satellite-based navigation system. The department prefers that a GPS receiver is used at the outfall pipe and the displayed coordinates submitted. If access to a GPS receiver is not available, use a mapping system to approximate the coordinates; the department's mapping system is available at <https://modnr.maps.arcgis.com/apps/webappviewer/index.html?id=1d81212e0854478ca0dae87c33c8c5ce>.

2.3-2.4 Self-explanatory

3. Owner – Provide the legal name, mailing address, phone number, and email address of the owner. The owner identified in this section and subsequently reflected on the certificate page of the operating permit, is the owner of the regulated activity/discharge being applied for and is not necessarily the owner of the real property on which the activity or discharge is occurring.

Prior to submitting a permit to public notice, the Department of Natural Resources shall provide the permit applicant 10 days to review the draft permit for nonsubstantive drafting errors. In the interest of expediting permit issuance, permit applicants may waive the opportunity to review draft permits prior to public notice.

3.2-3.4 Self-explanatory. The Financial Questionnaire is available at: <https://dnr.mo.gov/forms/780-2511-f.pdf>

4. Continuing Authority - A continuing authority is a company, business, entity or person(s) that will be operating the facility and/or ensuring compliance with the permit requirements. A continuing authority is not, however, an entity or individual that is contractually hired by the permittee to sample or operate and maintain the system for a defined time period, such as a certified operator or analytical laboratory. To access the regulatory requirement regarding continuing authority, 10 CSR 20-6.010(2), please visit <http://s1.sos.mo.gov/cmsimages/adrules/csr/current/10csr/10c20-6.pdf>. If the continuing authority is not an individual(s), government, or otherwise required to register with the Missouri Secretary of State (SoS), then the business name must be listed exactly as it appears on the SoS's webpage:

<https://bsd.sos.mo.gov/BusinessEntity/BESearch.aspx?SearchType=0>

5. Operator – Provide the name, certificate number, title, mailing address, primary phone number, and e-mail address of the operator of the facility.

6. Provide the name, title, mailing address, primary phone number, and e-mail address of a person who is thoroughly familiar with the operation of the facility and with the facts reported in this application and who can be contacted by the department.

7.1 Process Flow Diagram Examples

WASTEWATER TREATMENT LAGOON

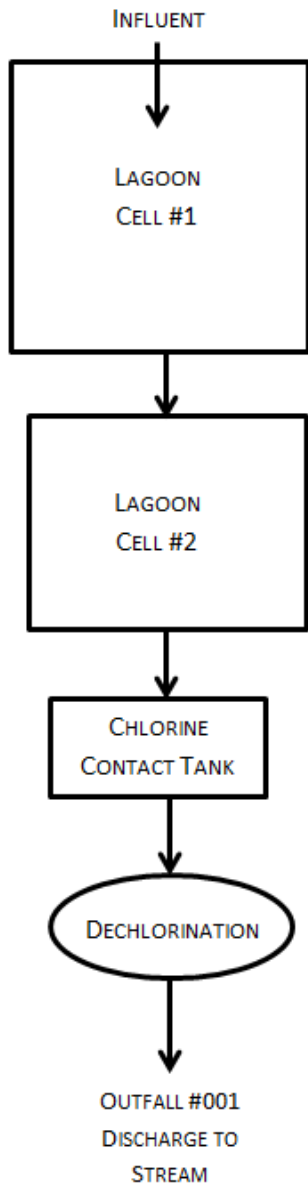

WASTEWATER TREATMENT FACILITY

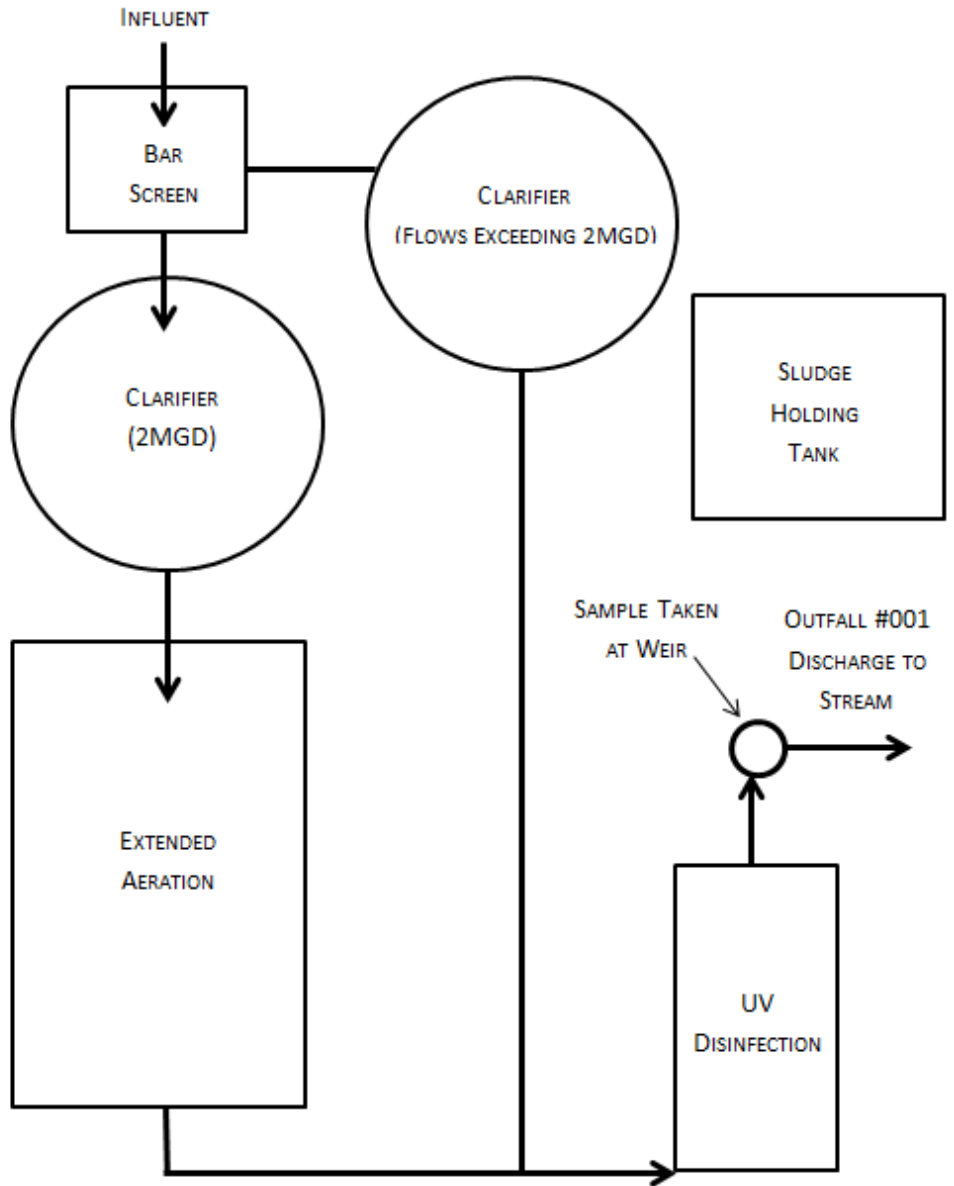

7.2 A topographic map is available on the Web at <https://modnr.maps.arcgis.com/apps/webappviewer/index.html?id=1d81212e0854478ca0dae87c33c8c5ce> or from the Department of Natural Resources' Geological Survey Division in Rolla at 573-368-2125.

8.1-8.6 Self-explanatory.

8.7 If wastewater is land applied submit Form I: [www.dnr.mo.gov/forms/780-1686-f.pdf](http://www.dnr.mo.gov/forms/780-1686-f.pdf).

8.9-8.9 Self-explanatory

**INSTRUCTIONS FOR COMPLETING FORM B: APPLICATION FOR OPERATING PERMIT FOR FACILITIES  
THAT RECEIVE PRIMARILY DOMESTIC WASTE AND HAVE A DESIGN FLOW  
LESS THAN OR EQUAL TO 100,000 GALLONS PER DAY (continued)**

9. Self-explanatory.
- 10.1 Self-explanatory.
- 10.2 Self-explanatory.
- 10.3 If Inflow and Infiltration (I&I) is a problem at the facility, list possible actions to be taken to repair the collection and treatment facility.
11. Include overflows of combined sewers and lift stations or bypassing of the wastewater treatment facility. Provide a detailed description of the circumstances that sewage bypassing occurs and the frequency of occurrence.
12. A copy of 10 CSR 25 is available on the Web at [www.sos.mo.gov/adrules/csr/current/10csr/10csr.asp#10-25](http://www.sos.mo.gov/adrules/csr/current/10csr/10csr.asp#10-25).
- 12.1-12.8 Self-explanatory.
- 12.9 Refer to University of Missouri Extension Environmental Quality publications about biosolids (WQ420-WQ426). The documents are available at [extension.missouri.edu/main/DisplayCategory.aspx?C=74](http://extension.missouri.edu/main/DisplayCategory.aspx?C=74). In addition, the federal sludge regulations are available through the U.S. Government Printing Office at <https://www.gpo.gov/fdsys/browse/collectionCfr.action?collectionCode=CFR>.
13. Electronic Discharge Monitoring Report (eDMR) Submission System – Visit the eDMR site at <http://dnr.mo.gov/env/wpp/edmr.htm> and click on the “Facility Participation Package” link. The eDMR Permit Holder and Certifier Registration Form and information about the eDMR system can be found in the Facility Participation Package. Waivers to electronic reporting may be granted by the Department per 40 CFR 127.15 under certain, special circumstances. A written request must be submitted to the Department for approval. Waivers may be granted to facilities owned or operated by:
- members of religious communities that choose not to use certain technologies.
  - permittees located in areas with limited broadband access. The National Telecommunications and Information Administration (NTIA) in collaboration with the Federal Communications Commission (FCC) have created a broadband internet availability map: <https://broadbandmap.fcc.gov/#/>. Please contact the department if you need assistance.
14. JETPAY
- Applicants can pay fees online by credit card or eCheck through a system called JetPay.
- Per Section 37.001, RSMo, a transaction fee will be included. The transaction fee is paid to the third party vendor JetPay, not the Department of Natural Resources.
  - Be sure to select the correct fee type and corresponding URL to ensure your payment is applied appropriately. If you are unsure what type of fee to pay, please contact the Water Protection Program’s Budget, Fees, and Grants Management Unit by phone at (573) 522-1485 for assistance.
  - Upon successful completion of your payment, JetPay provides a payment confirmation. Submit this form with a copy of the payment confirmation if requesting a new permit or a permit modification. For permit renewals of active permits, the Department will invoice fees annually in a separate request.
  - If you are unable to make your payment online, but want to pay with credit card, you may email your name, phone number, and invoice number, if applicable, to [sherry.bell@dnr.mo.gov](mailto:sherry.bell@dnr.mo.gov). The Budget, Fees, and Grants Management Unit will contact you to assist with the credit card payment. **Please do not include your credit card information in the email.**
  - Applicants can find fee rates in 10 CSR 20-6.011 (<https://dnr.mo.gov/pubs/pub2564.htm>).
15. CERTIFICATION
- Signature - All applications must be signed as follows and the signatures must be **handwritten**:
- For a corporation, by an officer having responsibility for the overall operation of the regulated facility or activity or for environmental matters.
  - For a partnership or sole proprietorship, by a general partner or the proprietor.
  - For a municipal, state, federal or other public facility, by either a principal executive officer or by an individual having overall responsibility for environmental matters at the facility.

**Submittal of an incomplete application may result in the application being returned.**

This completed form and any attachments along with the applicable permit fees, should be submitted to:  
[cleanwaterpermits@dnr.mo.gov](mailto:cleanwaterpermits@dnr.mo.gov)

OR

Department of Natural Resources  
Water Protection Program  
ATTN: NPDES Permits and Engineering Section  
P.O. Box 176  
Jefferson City, MO 65102

Map of regional offices with addresses and phone numbers are available on the Web at <http://dnr.mo.gov/regions/>. If there are any questions concerning this form, contact the appropriate regional office or the Department of Natural Resources, Water Protection Program, Operating Permits Section at 800-361-4827 or 573-522-4502.



STANDARD CONDITIONS FOR NPDES PERMITS  
ISSUED BY  
THE MISSOURI DEPARTMENT OF NATURAL RESOURCES  
MISSOURI CLEAN WATER COMMISSION  
REVISED  
AUGUST 1, 2014

These Standard Conditions incorporate permit conditions as required by 40 CFR 122.41 or other applicable state statutes or regulations. These minimum conditions apply unless superseded by requirements specified in the permit.

## Part I – General Conditions

### Section A – Sampling, Monitoring, and Recording

1. **Sampling Requirements.**
  - a. Samples and measurements taken for the purpose of monitoring shall be representative of the monitored activity.
  - b. All samples shall be taken at the outfall(s) or Missouri Department of Natural Resources (Department) approved sampling location(s), and unless specified, before the effluent joins or is diluted by any other body of water or substance.
2. **Monitoring Requirements.**
  - a. Records of monitoring information shall include:
    - i. The date, exact place, and time of sampling or measurements;
    - ii. The individual(s) who performed the sampling or measurements;
    - iii. The date(s) analyses were performed;
    - iv. The individual(s) who performed the analyses;
    - v. The analytical techniques or methods used; and
    - vi. The results of such analyses.
  - b. If the permittee monitors any pollutant more frequently than required by the permit at the location specified in the permit using test procedures approved under 40 CFR Part 136, or another method required for an industry-specific waste stream under 40 CFR subchapters N or O, the results of such monitoring shall be included in the calculation and reported to the Department with the discharge monitoring report data (DMR) submitted to the Department pursuant to Section B, paragraph 7.
3. **Sample and Monitoring Calculations.** Calculations for all sample and monitoring results which require averaging of measurements shall utilize an arithmetic mean unless otherwise specified in the permit.
4. **Test Procedures.** The analytical and sampling methods used shall conform to the reference methods listed in 10 CSR 20-7.015 unless alternates are approved by the Department. The facility shall use sufficiently sensitive analytical methods for detecting, identifying, and measuring the concentrations of pollutants. The facility shall ensure that the selected methods are able to quantify the presence of pollutants in a given discharge at concentrations that are low enough to determine compliance with Water Quality Standards in 10 CSR 20-7.031 or effluent limitations unless provisions in the permit allow for other alternatives. A method is “sufficiently sensitive” when; 1) the method minimum level is at or below the level of the applicable water quality criterion for the pollutant or, 2) the method minimum level is above the applicable water quality criterion, but the amount of pollutant in a facility’s discharge is high enough that the method detects and quantifies the level of pollutant in the discharge, or 3) the method has the lowest minimum level of the analytical methods approved under 10 CSR 20-7.015. These methods are also required for parameters that are listed as monitoring only, as the data collected may be used to determine if limitations need to be established. A permittee is responsible for working with their contractors to ensure that the analysis performed is sufficiently sensitive.
5. **Record Retention.** Except for records of monitoring information required by the permit related to the permittee's sewage sludge use and disposal activities, which shall be retained for a period of at least five (5) years (or longer as required by 40 CFR part 503), the permittee shall retain records of all monitoring information, including all calibration and maintenance records and all original strip chart recordings for continuous monitoring instrumentation, copies of all reports required by the permit, and records of all data used to complete the application for the permit, for a period of at least three (3) years from the date of the sample, measurement, report or application. This period may be extended by request of the Department at any time.

6. **Illegal Activities.**
  - a. The Federal Clean Water Act provides that any person who falsifies, tampers with, or knowingly renders inaccurate any monitoring device or method required to be maintained under the permit shall, upon conviction, be punished by a fine of not more than \$10,000, or by imprisonment for not more than two (2) years, or both. If a conviction of a person is for a violation committed after a first conviction of such person under this paragraph, punishment is a fine of not more than \$20,000 per day of violation, or by imprisonment of not more than four (4) years, or both.
  - b. The Missouri Clean Water Law provides that any person or who falsifies, tampers with, or knowingly renders inaccurate any monitoring device or method required to be maintained pursuant to sections 644.006 to 644.141 shall, upon conviction, be punished by a fine of not more than \$10,000, or by imprisonment for not more than six (6) months, or by both. Second and successive convictions for violation under this paragraph by any person shall be punished by a fine of not more than \$50,000 per day of violation, or by imprisonment for not more than two (2) years, or both.

### Section B – Reporting Requirements

1. **Planned Changes.**
  - a. The permittee shall give notice to the Department as soon as possible of any planned physical alterations or additions to the permitted facility when:
    - i. The alteration or addition to a permitted facility may meet one of the criteria for determining whether a facility is a new source in 40 CFR 122.29(b); or
    - ii. The alteration or addition could significantly change the nature or increase the quantity of pollutants discharged. This notification applies to pollutants which are subject neither to effluent limitations in the permit, nor to notification requirements under 40 CFR 122.42;
    - iii. The alteration or addition results in a significant change in the permittee's sludge use or disposal practices, and such alteration, addition, or change may justify the application of permit conditions that are different from or absent in the existing permit, including notification of additional use or disposal sites not reported during the permit application process or not reported pursuant to an approved land application plan;
  - iv. Any facility expansions, production increases, or process modifications which will result in a new or substantially different discharge or sludge characteristics must be reported to the Department 60 days before the facility or process modification begins. Notification may be accomplished by application for a new permit. If the discharge does not violate effluent limitations specified in the permit, the facility is to submit a notice to the Department of the changed discharge at least 30 days before such changes. The Department may require a construction permit and/or permit modification as a result of the proposed changes at the facility.
2. **Non-compliance Reporting.**
  - a. The permittee shall report any noncompliance which may endanger health or the environment. Relevant information shall be provided orally or via the current electronic method approved by the Department, within 24 hours from the time the permittee becomes aware of the circumstances, and shall be reported to the appropriate Regional Office during normal business hours or the Environmental Emergency Response hotline at 573-634-2436 outside of normal business hours. A written submission shall also be provided within five (5) business days of the time the permittee becomes aware of the circumstances. The written submission shall contain a description of the noncompliance and its cause; the period of noncompliance, including exact dates and times, and if the noncompliance has not been corrected, the anticipated time it is expected to continue; and steps taken or planned to reduce, eliminate, and prevent reoccurrence of the noncompliance.



STANDARD CONDITIONS FOR NPDES PERMITS  
ISSUED BY  
THE MISSOURI DEPARTMENT OF NATURAL RESOURCES  
MISSOURI CLEAN WATER COMMISSION  
REVISED  
AUGUST 1, 2014

- b. The following shall be included as information which must be reported within 24 hours under this paragraph.
    - i. Any unanticipated bypass which exceeds any effluent limitation in the permit.
    - ii. Any upset which exceeds any effluent limitation in the permit.
    - iii. Violation of a maximum daily discharge limitation for any of the pollutants listed by the Department in the permit required to be reported within 24 hours.
  - c. The Department may waive the written report on a case-by-case basis for reports under paragraph 2. b. of this section if the oral report has been received within 24 hours.
3. **Anticipated Noncompliance.** The permittee shall give advance notice to the Department of any planned changes in the permitted facility or activity which may result in noncompliance with permit requirements. The notice shall be submitted to the Department 60 days prior to such changes or activity.
  4. **Compliance Schedules.** Reports of compliance or noncompliance with, or any progress reports on, interim and final requirements contained in any compliance schedule of the permit shall be submitted no later than 14 days following each schedule date. The report shall provide an explanation for the instance of noncompliance and a proposed schedule or anticipated date, for achieving compliance with the compliance schedule requirement.
  5. **Other Noncompliance.** The permittee shall report all instances of noncompliance not reported under paragraphs 2, 3, and 6 of this section, at the time monitoring reports are submitted. The reports shall contain the information listed in paragraph 2. a. of this section.
  6. **Other Information.** Where the permittee becomes aware that it failed to submit any relevant facts in a permit application, or submitted incorrect information in a permit application or in any report to the Department, it shall promptly submit such facts or information.
  7. **Discharge Monitoring Reports.**
    - a. Monitoring results shall be reported at the intervals specified in the permit.
    - b. Monitoring results must be reported to the Department via the current method approved by the Department, unless the permittee has been granted a waiver from using the method. If the permittee has been granted a waiver, the permittee must use forms provided by the Department.
    - c. Monitoring results shall be reported to the Department no later than the 28<sup>th</sup> day of the month following the end of the reporting period.
- b. Notice.
    - i. Anticipated bypass. If the permittee knows in advance of the need for a bypass, it shall submit prior notice, if possible at least 10 days before the date of the bypass.
    - ii. Unanticipated bypass. The permittee shall submit notice of an unanticipated bypass as required in Section B – Reporting Requirements, paragraph 5 (24-hour notice).
  - c. Prohibition of bypass.
    - i. Bypass is prohibited, and the Department may take enforcement action against a permittee for bypass, unless:
      1. Bypass was unavoidable to prevent loss of life, personal injury, or severe property damage;
      2. There were no feasible alternatives to the bypass, such as the use of auxiliary treatment facilities, retention of untreated wastes, or maintenance during normal periods of equipment downtime. This condition is not satisfied if adequate back-up equipment should have been installed in the exercise of reasonable engineering judgment to prevent a bypass which occurred during normal periods of equipment downtime or preventive maintenance; and
      3. The permittee submitted notices as required under paragraph 2. b. of this section.
    - ii. The Department may approve an anticipated bypass, after considering its adverse effects, if the Department determines that it will meet the three (3) conditions listed above in paragraph 2. c. i. of this section.
3. **Upset Requirements.**
    - a. Effect of an upset. An upset constitutes an affirmative defense to an action brought for noncompliance with such technology based permit effluent limitations if the requirements of paragraph 3. b. of this section are met. No determination made during administrative review of claims that noncompliance was caused by upset, and before an action for noncompliance, is final administrative action subject to judicial review.
    - b. Conditions necessary for a demonstration of upset. A permittee who wishes to establish the affirmative defense of upset shall demonstrate, through properly signed, contemporaneous operating logs, or other relevant evidence that:
      - i. An upset occurred and that the permittee can identify the cause(s) of the upset;
      - ii. The permitted facility was at the time being properly operated; and
      - iii. The permittee submitted notice of the upset as required in Section B – Reporting Requirements, paragraph 2. b. ii. (24-hour notice).
      - iv. The permittee complied with any remedial measures required under Section D – Administrative Requirements, paragraph 4.
    - c. Burden of proof. In any enforcement proceeding, the permittee seeking to establish the occurrence of an upset has the burden of proof.

## Section C – Bypass/Upset Requirements

1. **Definitions.**
  - a. *Bypass*: the intentional diversion of waste streams from any portion of a treatment facility, except in the case of blending.
  - b. *Severe Property Damage*: substantial physical damage to property, damage to the treatment facilities which causes them to become inoperable, or substantial and permanent loss of natural resources which can reasonably be expected to occur in the absence of a bypass. Severe property damage does not mean economic loss caused by delays in production.
  - c. *Upset*: an exceptional incident in which there is unintentional and temporary noncompliance with technology based permit effluent limitations because of factors beyond the reasonable control of the permittee. An upset does not include noncompliance to the extent caused by operational error, improperly designed treatment facilities, inadequate treatment facilities, lack of preventive maintenance, or careless or improper operation.
2. **Bypass Requirements.**
  - a. Bypass not exceeding limitations. The permittee may allow any bypass to occur which does not cause effluent limitations to be exceeded, but only if it also is for essential maintenance to assure efficient operation. These bypasses are not subject to the provisions of paragraphs 2. b. and 2. c. of this section.

## Section D – Administrative Requirements

1. **Duty to Comply.** The permittee must comply with all conditions of this permit. Any permit noncompliance constitutes a violation of the Missouri Clean Water Law and Federal Clean Water Act and is grounds for enforcement action; for permit termination, revocation and reissuance, or modification; or denial of a permit renewal application.
  - a. The permittee shall comply with effluent standards or prohibitions established under section 307(a) of the Federal Clean Water Act for toxic pollutants and with standards for sewage sludge use or disposal established under section 405(d) of the CWA within the time provided in the regulations that establish these standards or prohibitions or standards for sewage sludge use or disposal, even if the permit has not yet been modified to incorporate the requirement.
  - b. The Federal Clean Water Act provides that any person who violates section 301, 302, 306, 307, 308, 318 or 405 of the Act, or any permit condition or limitation implementing any such sections in a permit issued under section 402, or any requirement imposed in a pretreatment program approved under sections 402(a)(3) or 402(b)(8) of the Act, is subject to a civil penalty not to exceed \$25,000 per day for each violation. The Federal Clean Water Act provides that any person who negligently violates sections 301, 302, 306, 307, 308, 318, or 405 of the Act, or any condition or limitation implementing any of such sections in a permit issued under section 402 of the Act, or any requirement





STANDARD CONDITIONS FOR NPDES PERMITS  
ISSUED BY  
THE MISSOURI DEPARTMENT OF NATURAL RESOURCES  
MISSOURI CLEAN WATER COMMISSION  
REVISED  
AUGUST 1, 2014

- imposed in a pretreatment program approved under section 402(a)(3) or 402(b)(8) of the Act, is subject to criminal penalties of \$2,500 to \$25,000 per day of violation, or imprisonment of not more than one (1) year, or both. In the case of a second or subsequent conviction for a negligent violation, a person shall be subject to criminal penalties of not more than \$50,000 per day of violation, or by imprisonment of not more than two (2) years, or both. Any person who knowingly violates such sections, or such conditions or limitations is subject to criminal penalties of \$5,000 to \$50,000 per day of violation, or imprisonment for not more than three (3) years, or both. In the case of a second or subsequent conviction for a knowing violation, a person shall be subject to criminal penalties of not more than \$100,000 per day of violation, or imprisonment of not more than six (6) years, or both. Any person who knowingly violates section 301, 302, 303, 306, 307, 308, 318 or 405 of the Act, or any permit condition or limitation implementing any of such sections in a permit issued under section 402 of the Act, and who knows at that time that he thereby places another person in imminent danger of death or serious bodily injury, shall, upon conviction, be subject to a fine of not more than \$250,000 or imprisonment of not more than 15 years, or both. In the case of a second or subsequent conviction for a knowing endangerment violation, a person shall be subject to a fine of not more than \$500,000 or by imprisonment of not more than 30 years, or both. An organization, as defined in section 309(c)(3)(B)(iii) of the CWA, shall, upon conviction of violating the imminent danger provision, be subject to a fine of not more than \$1,000,000 and can be fined up to \$2,000,000 for second or subsequent convictions.
- c. Any person may be assessed an administrative penalty by the EPA Director for violating section 301, 302, 306, 307, 308, 318 or 405 of this Act, or any permit condition or limitation implementing any of such sections in a permit issued under section 402 of this Act. Administrative penalties for Class I violations are not to exceed \$10,000 per violation, with the maximum amount of any Class I penalty assessed not to exceed \$25,000. Penalties for Class II violations are not to exceed \$10,000 per day for each day during which the violation continues, with the maximum amount of any Class II penalty not to exceed \$125,000.
- d. It is unlawful for any person to cause or permit any discharge of water contaminants from any water contaminant or point source located in Missouri in violation of sections 644.006 to 644.141 of the Missouri Clean Water Law, or any standard, rule or regulation promulgated by the commission. In the event the commission or the director determines that any provision of sections 644.006 to 644.141 of the Missouri Clean Water Law or standard, rules, limitations or regulations promulgated pursuant thereto, or permits issued by, or any final abatement order, other order, or determination made by the commission or the director, or any filing requirement pursuant to sections 644.006 to 644.141 of the Missouri Clean Water Law or any other provision which this state is required to enforce pursuant to any federal water pollution control act, is being, was, or is in imminent danger of being violated, the commission or director may cause to have instituted a civil action in any court of competent jurisdiction for the injunctive relief to prevent any such violation or further violation or for the assessment of a penalty not to exceed \$10,000 per day for each day, or part thereof, the violation occurred and continues to occur, or both, as the court deems proper. Any person who willfully or negligently commits any violation in this paragraph shall, upon conviction, be punished by a fine of not less than \$2,500 nor more than \$25,000 per day of violation, or by imprisonment for not more than one year, or both. Second and successive convictions for violation of the same provision of this paragraph by any person shall be punished by a fine of not more than \$50,000 per day of violation, or by imprisonment for not more than two (2) years, or both.
2. **Duty to Reapply.**
- a. If the permittee wishes to continue an activity regulated by this permit after the expiration date of this permit, the permittee must apply for and obtain a new permit.
- b. A permittee with a currently effective site-specific permit shall submit an application for renewal at least 180 days before the expiration date of the existing permit, unless permission for a later date has been granted by the Department. (The Department shall not grant permission for applications to be submitted later than the expiration date of the existing permit.)
- c. A permittees with currently effective general permit shall submit an application for renewal at least 30 days before the existing permit expires, unless the permittee has been notified by the Department that an earlier application must be made. The Department may grant permission for a later submission date. (The Department shall not grant permission for applications to be submitted later than the expiration date of the existing permit.)
3. **Need to Halt or Reduce Activity Not a Defense.** It shall not be a defense for a permittee in an enforcement action that it would have been necessary to halt or reduce the permitted activity in order to maintain compliance with the conditions of this permit.
4. **Duty to Mitigate.** The permittee shall take all reasonable steps to minimize or prevent any discharge or sludge use or disposal in violation of this permit which has a reasonable likelihood of adversely affecting human health or the environment.
5. **Proper Operation and Maintenance.** The permittee shall at all times properly operate and maintain all facilities and systems of treatment and control (and related appurtenances) which are installed or used by the permittee to achieve compliance with the conditions of this permit. Proper operation and maintenance also includes adequate laboratory controls and appropriate quality assurance procedures. This provision requires the operation of back-up or auxiliary facilities or similar systems which are installed by a permittee only when the operation is necessary to achieve compliance with the conditions of the permit.
6. **Permit Actions.**
- a. Subject to compliance with statutory requirements of the Law and Regulations and applicable Court Order, this permit may be modified, suspended, or revoked in whole or in part during its term for cause including, but not limited to, the following:
- i. Violations of any terms or conditions of this permit or the law;
- ii. Having obtained this permit by misrepresentation or failure to disclose fully any relevant facts;
- iii. A change in any circumstances or conditions that requires either a temporary or permanent reduction or elimination of the authorized discharge; or
- iv. Any reason set forth in the Law or Regulations.
- b. The filing of a request by the permittee for a permit modification, revocation and reissuance, or termination, or a notification of planned changes or anticipated noncompliance does not stay any permit condition.
7. **Permit Transfer.**
- a. Subject to 10 CSR 20-6.010, an operating permit may be transferred upon submission to the Department of an application to transfer signed by the existing owner and the new owner, unless prohibited by the terms of the permit. Until such time the permit is officially transferred, the original permittee remains responsible for complying with the terms and conditions of the existing permit.
- b. The Department may require modification or revocation and reissuance of the permit to change the name of the permittee and incorporate such other requirements as may be necessary under the Missouri Clean Water Law or the Federal Clean Water Act.
- c. The Department, within 30 days of receipt of the application, shall notify the new permittee of its intent to revoke or reissue or transfer the permit.
8. **Toxic Pollutants.** The permittee shall comply with effluent standards or prohibitions established under section 307(a) of the Federal Clean Water Act for toxic pollutants and with standards for sewage sludge use or disposal established under section 405(d) of the Federal Clean Water Act within the time provided in the regulations that establish these standards or prohibitions or standards for sewage sludge use or disposal, even if the permit has not yet been modified to incorporate the requirement.
9. **Property Rights.** This permit does not convey any property rights of any sort, or any exclusive privilege.



STANDARD CONDITIONS FOR NPDES PERMITS  
ISSUED BY  
THE MISSOURI DEPARTMENT OF NATURAL RESOURCES  
MISSOURI CLEAN WATER COMMISSION  
REVISED  
AUGUST 1, 2014

10. **Duty to Provide Information.** The permittee shall furnish to the Department, within a reasonable time, any information which the Department may request to determine whether cause exists for modifying, revoking and reissuing, or terminating this permit or to determine compliance with this permit. The permittee shall also furnish to the Department upon request, copies of records required to be kept by this permit.
11. **Inspection and Entry.** The permittee shall allow the Department, or an authorized representative (including an authorized contractor acting as a representative of the Department), upon presentation of credentials and other documents as may be required by law, to:
  - a. Enter upon the permittee's premises where a regulated facility or activity is located or conducted, or where records must be kept under the conditions of the permit;
  - b. Have access to and copy, at reasonable times, any records that must be kept under the conditions of this permit;
  - c. Inspect at reasonable times any facilities, equipment (including monitoring and control equipment), practices, or operations regulated or required under this permit; and
  - d. Sample or monitor at reasonable times, for the purposes of assuring permit compliance or as otherwise authorized by the Federal Clean Water Act or Missouri Clean Water Law, any substances or parameters at any location.
12. **Closure of Treatment Facilities.**
  - a. Persons who cease operation or plan to cease operation of waste, wastewater, and sludge handling and treatment facilities shall close the facilities in accordance with a closure plan approved by the Department.
  - b. Operating Permits under 10 CSR 20-6.010 or under 10 CSR 20-6.015 are required until all waste, wastewater, and sludges have been disposed of in accordance with the closure plan approved by the Department and any disturbed areas have been properly stabilized. Disturbed areas will be considered stabilized when perennial vegetation, pavement, or structures using permanent materials cover all areas that have been disturbed. Vegetative cover, if used, shall be at least 70% plant density over 100% of the disturbed area.
13. **Signatory Requirement.**
  - a. All permit applications, reports required by the permit, or information requested by the Department shall be signed and certified. (See 40 CFR 122.22 and 10 CSR 20-6.010)
  - b. The Federal Clean Water Act provides that any person who knowingly makes any false statement, representation, or certification in any record or other document submitted or required to be maintained under this permit, including monitoring reports or reports of compliance or non-compliance shall, upon conviction, be punished by a fine of not more than \$10,000 per violation, or by imprisonment for not more than six (6) months per violation, or by both.
  - c. The Missouri Clean Water Law provides that any person who knowingly makes any false statement, representation or certification in any application, record, report, plan, or other document filed or required to be maintained pursuant to sections 644.006 to 644.141 shall, upon conviction, be punished by a fine of not more than ten thousand dollars, or by imprisonment for not more than six months, or by both.
14. **Severability.** The provisions of the permit are severable, and if any provision of the permit, or the application of any provision of the permit to any circumstance, is held invalid, the application of such provision to other circumstances, and the remainder of the permit, shall not be affected thereby.

**STANDARD CONDITIONS FOR NPDES PERMITS  
ISSUED BY  
THE MISSOURI DEPARTMENT OF NATURAL RESOURCES  
MISSOURI CLEAN WATER COMMISSION  
August 1, 2019**

**PART III – BIOSOLIDS AND SLUDGE FROM DOMESTIC TREATMENT FACILITIES**

**SECTION A – GENERAL REQUIREMENTS**

1. PART III Standard Conditions pertain to biosolids and sludge requirements under the Missouri Clean Water Law and regulations for domestic and municipal wastewater and also incorporates federal sludge disposal requirements under 40 CFR Part 503 for domestic wastewater. The Environmental Protection Agency (EPA) has principal authority for permitting and enforcement of the federal sludge regulations under 40 CFR Part 503 for domestic biosolids and sludge.
2. PART III Standard Conditions apply only to biosolids and sludge generated at domestic wastewater treatment facilities, including public owned treatment works (POTW) and privately owned facilities.
3. Biosolids and Sludge Use and Disposal Practices:
  - a. The permittee is authorized to operate the biosolids and sludge generating, treatment, storage, use, and disposal facilities listed in the facility description of this permit.
  - b. The permittee shall not exceed the design sludge/biosolids volume listed in the facility description and shall not use biosolids or sludge disposal methods that are not listed in the facility description, without prior approval of the permitting authority.
  - c. For facilities operating under general operating permits that incorporate Standard Conditions PART III, the facility is authorized to operate the biosolids and sludge generating, treatment, storage, use and disposal facilities identified in the original operating permit application, subsequent renewal applications or subsequent written approval by the department.
4. Biosolids or Sludge Received from other Facilities:
  - a. Permittees may accept domestic wastewater biosolids or sludge from other facilities as long as the permittee's design sludge capacity is not exceeded and the treatment facility performance is not impaired.
  - b. The permittee shall obtain a signed statement from the biosolids or sludge generator or hauler that certifies the type and source of the sludge
5. Nothing in this permit precludes the initiation of legal action under local laws, except to the extent local laws are preempted by state law.
6. This permit does not preclude the enforcement of other applicable environmental regulations such as odor emissions under the Missouri Air Pollution Control Law and regulations.
7. This permit may (after due process) be modified, or alternatively revoked and reissued, to comply with any applicable biosolids or sludge disposal standard or limitation issued or approved under Section 405(d) of the Clean Water Act or under Chapter 644 RSMo.
8. In addition to Standard Conditions PART III, the Department may include biosolids and sludge limitations in the special conditions portion or other sections of a site specific permit.
9. Exceptions to Standard Conditions PART III may be authorized on a case-by-case basis by the Department, as follows:
  - a. The Department may modify a site-specific permit following permit notice provisions as applicable under 10 CSR 20-6.020, 40 CFR § 124.10, and 40 CFR § 501.15(a)(2)(ix)(E).
  - b. Exceptions cannot be granted where prohibited by the federal sludge regulations under 40 CFR Part 503.

## **SECTION B – DEFINITIONS**

1. Best Management Practices are practices to prevent or reduce the pollution of waters of the state and include agronomic loading rates (nitrogen based), soil conservation practices, spill prevention and maintenance procedures and other site restrictions.
2. Biosolids means organic fertilizer or soil amendment produced by the treatment of domestic wastewater sludge.
3. Biosolids land application facility is a facility where biosolids are spread onto the land at agronomic rates for production of food, feed or fiber. The facility includes any structures necessary to store the biosolids until soil, weather, and crop conditions are favorable for land application.
4. Class A biosolids means a material that has met the Class A pathogen reduction requirements or equivalent treatment by a Process to Further Reduce Pathogens (PFRP) in accordance with 40 CFR Part 503.
5. Class B biosolids means a material that has met the Class B pathogen reduction requirements or equivalent treatment by a Process to Significantly Reduce Pathogens (PSRP) in accordance with 40 CFR Part 503.
6. Domestic wastewater means wastewater originating from the sanitary conveniences of residences, commercial buildings, factories and institutions; or co-mingled sanitary and industrial wastewater processed by a (POTW) or a privately owned facility.
7. Feed crops are crops produced primarily for consumption by animals.
8. Fiber crops are crops such as flax and cotton.
9. Food crops are crops consumed by humans which include, but is not limited to, fruits, vegetables and tobacco.
10. Industrial wastewater means any wastewater, also known as process wastewater, not defined as domestic wastewater. Per 40 CFR Part 122.2, process wastewater means any water which, during manufacturing or processing, comes into direct contact with or results from the production or use of any raw material, intermediate product, finished product, byproduct, or waste product. Land application of industrial wastewater, residuals or sludge is not authorized by Standard Conditions PART III.
11. Mechanical treatment plants are wastewater treatment facilities that use mechanical devices to treat wastewater, including, sand filters, extended aeration, activated sludge, contact stabilization, trickling filters, rotating biological contact systems, and other similar facilities. It does not include wastewater treatment lagoons or constructed wetlands for wastewater treatment.
12. Plant Available Nitrogen (PAN) is nitrogen that will be available to plants during the growing seasons after biosolids application.
13. Public contact site is land with a high potential for contact by the public. This includes, but is not limited to, public parks, ball fields, cemeteries, plant nurseries, turf farms, and golf courses.
14. Sludge is the solid, semisolid, or liquid residue removed during the treatment of wastewater. Sludge includes septage removed from septic tanks or equivalent facilities. Sludge does not include carbon coal byproducts (CCBs), sewage sludge incinerator ash, or grit/screenings generated during preliminary treatment of domestic sewage.
15. Sludge lagoon is part of a mechanical wastewater treatment facility. A sludge lagoon is an earthen or concrete lined basin that receives sludge that has been removed from a wastewater treatment facility. It does not include a wastewater treatment lagoon or sludge treatment units that are not a part of a mechanical wastewater treatment facility.
16. Septage is the sludge pumped from residential septic tanks, cesspools, portable toilets, Type III marine sanitation devices, or similar treatment works such as sludge holding structures from residential wastewater treatment facilities with design populations of less than 150 people. Septage does not include grease removed from grease traps at a restaurant or material removed from septic tanks and other similar treatment works that have received industrial wastewater. The standard for biosolids from septage is different from other sludges. See Section H for more information.

## **SECTION C – MECHANICAL WASTEWATER TREATMENT FACILITIES**

1. Biosolids or sludge shall be routinely removed from wastewater treatment facilities and handled according to the permit facility description and the requirements of Standard Conditions PART III or in accordance with Section A.3.c., above.
2. The permittee shall operate storage and treatment facilities, as defined by Section 644.016(23), RSMo, so that there is no biosolids or sludge discharged to waters of the state. Agricultural storm water discharges are exempt under the provisions of Section 644.059, RSMo.
3. Mechanical treatment plants shall have separate biosolids or sludge storage compartments in accordance with 10 CSR 20, Chapter 8. Failure to remove biosolids or sludge from these storage compartments on the required design schedule is a violation of this permit.

## **SECTION D – BIOSOLIDS OR SLUDGE DISPOSED AT OTHER TREATMENT FACILITY OR BY CONTRACT HAULER**

1. Permittees that use contract haulers, under the authority of their operating permit, to dispose of biosolids or sludge, are responsible for compliance with all the terms of this permit. Contract haulers that assume the responsibility of the final disposal of biosolids or sludge, including biosolids land application, must obtain a Missouri State Operating Permit unless the hauler transports the biosolids or sludge to another permitted treatment facility.
2. Testing of biosolids or sludge, other than total solids content, is not required if biosolids or sludge are hauled to a permitted wastewater treatment facility, unless it is required by the accepting facility.

## **SECTION E – INCINERATION OF SLUDGE**

1. Please be aware that sludge incineration facilities may be subject to the requirements of 40 CFR Part 503 Subpart E, Missouri Air Conservation Commission regulations under 10 CSR 10, and solid waste management regulations under 10 CSR 80, as applicable.
2. Permittee may be authorized under the facility description of this permit to store incineration ash in lagoons or ash ponds. This permit does not authorize the disposal of incineration ash. Incineration ash shall be disposed in accordance with 10 CSR 80; or, if the ash is determined to be hazardous, with 10 CSR 25.
3. In addition to normal sludge monitoring, incineration facilities shall report the following as part of the annual report, mass of sludge incinerated and mass of ash generated. Permittee shall also provide the name of the ash disposal facility and permit number if applicable.

## **SECTION F – SURFACE DISPOSAL SITES AND BIOSOLIDS AND SLUDGE LAGOONS**

1. Please be aware that surface disposal sites of biosolids or sludge from wastewater treatment facilities may be subject to other laws including the requirements in 40 CFR Part 503 Subpart C, Missouri Air Conservation Commission regulations under 10 CSR 10, and solid waste management regulations under 10 CSR 80, as applicable.
2. Biosolids or sludge storage lagoons are temporary facilities and are not required to obtain a permit as a solid waste management facility under 10 CSR 80. In order to maintain biosolids or sludge storage lagoons as storage facilities, accumulated biosolids or sludge must be removed routinely, but not less than once every two years unless an alternate schedule is approved in the permit. The amount of biosolids or sludge removed will be dependent on biosolids or sludge generation and accumulation in the facility. Enough biosolids or sludge must be removed to maintain adequate storage capacity in the facility.
  - a. In order to avoid damage to the lagoon seal during cleaning, the permittee may leave a layer of biosolids or sludge on the bottom of the lagoon, upon prior approval of the Department; or
  - b. Permittee shall close the lagoon in accordance with Section I.

## **SECTION G – LAND APPLICATION OF BIOSOLIDS**

1. The permittee shall not land apply biosolids unless land application is authorized in the facility description, the special conditions of the issued NPDES permit, or in accordance with Section A.3.c., above.
2. This permit only authorizes “Class A” or “Class B” biosolids derived from domestic wastewater to be land applied onto grass land, crop land, timber, or other similar agricultural or silviculture lands at rates suitable for beneficial use as organic fertilizer and soil conditioner.
3. Class A Biosolids Requirements: Biosolids shall meet Class A requirements for application to public contact sites, residential lawns, home gardens or sold and/or given away in a bag or other container.
4. Class B biosolids that are land applied to agricultural and public contact sites shall comply with the following restrictions:
  - a. Food crops that touch the biosolids/soil mixture and are totally above the land surface shall not be harvested for 14 months after application of biosolids.
  - b. Food crops below the surface of the land shall not be harvested for 20 months after application of biosolids when the biosolids remain on the land surface for four months or longer prior to incorporation into the soil.
  - c. Food crops below the surface of the land shall not be harvested for 38 months after application of biosolids when the biosolids remain on the land surface for less than four months prior to incorporation into the soil.
  - d. Animal grazing shall not be allowed for 30 days after application of biosolids.
  - e. Food crops, feed crops, and fiber crops shall not be harvested for 30 days after application of biosolids.
  - f. Turf shall not be harvested for one year after application of biosolids if used for lawns or high public contact sites in close proximity to populated areas such as city parks or golf courses.
  - g. After Class B biosolids have been land applied to public contact sites with high potential for public exposure, as defined in 40 CFR § 503.31, such as city parks or golf courses, access must be restricted for 12 months.
  - h. After Class B biosolids have been land applied public contact sites with low potential for public exposure as defined in 40 CFR § 503.31, such as a rural land application or reclamation sites, access must be restricted for 30 days.
5. Pollutant limits
  - a. Biosolids shall be monitored to determine the quality for regulated pollutants listed in Table 1, below. Limits for any pollutants not listed below may be established in the permit.
  - b. The number of samples taken is directly related to the amount of biosolids or sludge produced by the facility (See Section J, below). Samples should be taken only during land application periods. When necessary, it is permissible to mix biosolids with lower concentrations of biosolids as well as other suitable Department approved material to achieve pollutant concentration below those identified in Table 1, below.
  - c. Table 1 gives the ceiling concentration for biosolids. Biosolids which exceed the concentrations in Table 1 may not be land applied.

**TABLE 1**

Biosolids ceiling concentration	
Pollutant	Milligrams per kilogram dry weight
Arsenic	75
Cadmium	85
Copper	4,300
Lead	840
Mercury	57
Molybdenum	75
Nickel	420
Selenium	100
Zinc	7,500

- d. Table 2 below gives the low metal concentration for biosolids. Because of its higher quality, biosolids with pollutant concentrations below those listed in Table 2 can safely be applied to agricultural land, forest, public contact sites, lawns, home gardens or be given away without further analysis. Biosolids containing metals in concentrations above the low metals concentrations but below the ceiling concentration limits may be land applied but shall not exceed the annual loading rates in Table 3 and the cumulative loading rates in Table 4. The permittee is required to track pollutant loading onto application sites for parameters that have exceeded the low metal concentration limits.

**TABLE 2**

Biosolids Low Metal Concentration	
Pollutant	Milligrams per kilogram dry weight
Arsenic	41
Cadmium	39
Copper	1,500
Lead	300
Mercury	17
Nickel	420
Selenium	100
Zinc	2,800

- e. Annual pollutant loading rate.

**Table 3**

Biosolids Annual Loading Rate	
Pollutant	Kg/ha (lbs./ac) per year
Arsenic	2.0 (1.79)
Cadmium	1.9 (1.70)
Copper	75 (66.94)
Lead	15 (13.39)
Mercury	0.85 (0.76)
Nickel	21 (18.74)
Selenium	5.0 (4.46)
Zinc	140 (124.96)

- f. Cumulative pollutant loading rates.

**Table 4**

Biosolids Cumulative Pollutant Loading Rate	
Pollutant	Kg/ha (lbs./ac)
Arsenic	41 (37)
Cadmium	39 (35)
Copper	1500 (1339)
Lead	300 (268)
Mercury	17 (15)
Nickel	420 (375)
Selenium	100 (89)
Zinc	2800 (2499)

6. Best Management Practices. The permittee shall use the following best management practices during land application activities to prevent the discharge of biosolids to waters of the state.
- Biosolids shall not be applied to the land if it is likely to adversely affect a threatened or endangered species listed under § 4 of the Endangered Species Act or its designated critical habitat.
  - Apply biosolids only at the agronomic rate of nitrogen needed (see 5.c. of this section).
  - The applicator must document the Plant Available Nitrogen (PAN) loadings, available nitrogen in the soil, and crop

nitrogen removal when either of the following occurs: 1) When biosolids are greater than 50,000 mg/kgTN; or 2) When biosolids are land applied at an application rate greater than two dry tons per acre per year.

- i. PAN can be determined as follows:  
(Nitrate + nitrite nitrogen) + (organic nitrogen x 0.2) + (ammonia nitrogen x volatilization factor<sup>1</sup>).  
<sup>1</sup> Volatilization factor is 0.7 for surface application and 1 for subsurface application. Alternative volatilization factors and mineralization rates can be utilized on a case-by-case basis.
  - ii. Crop nutrient production/removal to be based on crop specific nitrogen needs and realistic yield goals. **NOTE:** There are a number of reference documents on the Missouri Department of Natural Resources website that are informative to implement best management practices in the proper management of biosolids, including crop specific nitrogen needs, realistic yields on a county by county basis and other supporting references.
  - iii. Biosolids that are applied at agronomic rates shall not cause the annual pollutant loading rates identified in Table 3 to be exceeded.
- d. Buffer zones are as follows:
- i. 300 feet of a water supply well, sinkhole, water supply reservoir or water supply intake in a stream;
  - ii. 300 feet of a losing stream, no discharge stream, stream stretches designated for whole body contact recreation, wild and scenic rivers, Ozark National Scenic Riverways or outstanding state resource waters as listed in the Water Quality Standards, 10 CSR 20-7.031;
  - iii. 150 feet of dwellings or public use areas;
  - iv. 100 feet (35 feet if biosolids application is down-gradient or the buffer zone is entirely vegetated) of lake, pond, wetlands or gaining streams (perennial or intermittent);
  - v. 50 feet of a property line. Buffer distances from property lines may be waived with written permission from neighboring property owner.
  - vi. For the application of dry, cake or liquid biosolids that are subsurface injected, buffer zones identified in 5.d.i. through 5.d.iii above, may be reduced to 100 feet. The buffer zone may be reduced to 35 feet if the buffer zone is permanently vegetated. Subsurface injection does not include methods or technology reflective of combination surface/shallow soil incorporation.
- e. Slope limitation for application sites are as follows:
- i. For slopes less than or equal to 6 percent, no rate limitation;
  - ii. Applied to a slope 7 to 12 percent, the applicator may apply biosolids when soil conservation practices are used to meet the minimum erosion levels;
  - iii. Slopes > 12 percent, apply biosolids only when grass is vegetated and maintained with at least 80 percent ground cover at a rate of two dry tons per acre per year or less.
  - iv. Dry, cake or liquid biosolids that are subsurface injected, may be applied on slopes not to exceed 20 percent. Subsurface injection does not include the use of methods or technology reflective of combination surface/shallow soil incorporation.
- f. No biosolids may be land applied in an area that it is reasonably certain that pollutants will be transported into waters of the state.
- g. Biosolids may be land applied to sites with soil that are snow covered, frozen, or saturated with liquid when site restrictions or other controls are provided to prevent pollutants from being discharged to waters of the state during snowmelt or stormwater runoff. During inclement weather or unfavorable soil conditions use the following management practices:
- i. A maximum field slope of 6% and a minimum 300 feet grass buffer between the application site and waters of the state. A 35 feet grass buffer may be utilized for the application of dry, cake or liquid biosolids that are subsurface injected. Subsurface injection does not include the use of methods or technology reflective of combination surface/shallow soil incorporation;
  - ii. A maximum field slope of 2% and 100 feet grass buffer between the application site and waters of the state. A 35 feet grass buffer may be used for the application of dry, cake or liquid biosolids that are subsurface injected. Subsurface injection does not include the use of methods or technology reflective of combination surface/shallow soil incorporation;
  - iii. Other best management practices approved by the Department.

## SECTION H – SEPTAGE

1. Haulers that land apply septage must obtain a state permit. An operating permit is not required for septage haulers who transport septage to another permitted treatment facility for disposal.
2. Do not apply more than 30,000 gallons of septage per acre per year or the volume otherwise stipulated in the operating permit.
3. Septic tanks are designed to retain sludge for one to three years which will allow for a larger reduction in pathogens and vectors, as compared to mechanical treatment facilities.
4. Septage must comply with Class B biosolids regarding pathogen and vector attraction reduction requirements before it may be applied to crops, pastures or timberland. To meet required pathogen and vector reduction requirements, mix 50 pounds of hydrated lime for every 1,000 gallons of septage and maintain a septage pH of at least 12 pH standard units for 30 minutes or more prior to application.
5. Lime is to be added to the pump truck and not directly to the septic tanks, as lime would harm the beneficial bacteria of the septic tank.
6. As residential septage contains relatively low levels of metals, the testing of metals in septage is not required.

## SECTION I – CLOSURE REQUIREMENTS

1. This section applies to all wastewater facilities (mechanical and lagoons) and sludge or biosolids storage and treatment facilities. It does not apply to land application sites.
2. Permittees of a domestic wastewater facility who plan to cease operation must obtain Department approval of a closure plan which addresses proper removal and disposal of all sludges and/or biosolids. Permittee must maintain this permit until the facility is closed in accordance with the approved closure plan per 10 CSR 20 – 6.010 and 10 CSR 20 – 6.015.
3. Biosolids or sludge that are left in place during closure of a lagoon or earthen structure or ash pond shall not exceed the agricultural loading rates as follows:
  - a. Biosolids and sludge shall meet the monitoring and land application limits for agricultural rates as referenced in Section G, above.
  - b. If a wastewater treatment lagoon has been in operation for 15 years or more without sludge removal, the sludge in the lagoon qualifies as a Class B biosolids with respect to pathogens due to anaerobic digestion, and testing for fecal coliform is not required. For other lagoons, testing for fecal coliform is required to show compliance with Class B biosolids limitations. In order to reach Class B biosolids requirements, fecal coliform must be less than 2,000,000 colony forming units or 2,000,000 most probable number. All fecal samples must be presented as geometric mean per gram.
  - c. The allowable nitrogen loading that may be left in the lagoon shall be based on the plant available nitrogen (PAN) loading. For a grass cover crop, the allowable PAN is 300 pounds/acre. Alternative, site-specific application rates may be included in the closure plan for department consideration.
    - i. PAN can be determined as follows:  
(Nitrate + nitrite nitrogen) + (organic nitrogen x 0.2) + (ammonia nitrogen x volatilization factor<sup>1</sup>).  
<sup>1</sup> Volatilization factor is 0.7 for surface application and 1 for subsurface application. Alternative volatilization factors and mineralization rates can be utilized on a case-by-case basis
4. Domestic wastewater treatment lagoons with a design treatment capacity less than or equal to 150 persons, are “similar treatment works” under the definition of septage. Therefore the sludge within the lagoons may be treated as septage during closure activities. See Section B, above. Under the septage category, residuals may be left in place as follows:
  - a. Testing for metals or fecal coliform is not required.
  - b. If the wastewater treatment lagoon has been in use for less than 15 years, mix lime with the sludge at a rate of 50 pounds of hydrated lime per 1000 gallons (134 cubic feet) of sludge.
  - c. The amount of sludge that may be left in the lagoon shall be based on the plant available nitrogen (PAN) loading. 100 dry tons/acre of sludge may be left in the basin without testing for nitrogen. If 100 dry tons/acre or more will be left in the lagoon, test for nitrogen and determine the PAN using the calculation above. Allowable PAN loading is 300 pounds/acre.
5. Biosolids or sludge left within the domestic lagoon shall be mixed with soil on at least a 1 to 1 ratio, and unless otherwise approved, the lagoon berm shall be demolished, and the site shall be graded and contain  $\geq 70\%$  vegetative density over 100% of the site so as to avoid ponding of storm water and provide adequate surface water drainage without creating erosion. Alternative biosolids or sludge and soil mixing ratios may be included in the closure plan for department consideration.
6. Lagoon and earthen structure closure activities shall obtain a storm water permit for land disturbance activities that equal or exceed one acre in accordance with 10 CSR 20-6.200.
7. When closing a mechanical wastewater plant, all biosolids or sludge must be cleaned out and disposed of in accordance with the Department approved closure plan before the permit for the facility can be terminated.
  - a. Land must be stabilized which includes any grading, alternate use or fate upon approval by the Department, remediation, or other work that exposes sediment to stormwater per 10 CSR 20-6.200. The site shall be graded and contain  $\geq 70\%$  vegetative density over 100% of the site, so as to avoid ponding of storm water and provide adequate



- surface water drainage without creating erosion.
  - b. Hazardous Waste shall not be land applied or disposed during mechanical plant closures unless in accordance with Missouri Hazardous Waste Management Law and Regulations pursuant to 10 CSR 25.
  - c. After demolition of the mechanical plant, the site must only contain clean fill defined in Section 260.200.1(6) RSMo as uncontaminated soil, rock, sand, gravel, concrete, asphaltic concrete, cinderblocks, brick, minimal amounts of wood and metal, and inert solids as approved by rule or policy of the Department for fill, reclamation, or other beneficial use. Other solid wastes must be removed.
8. If biosolids or sludge from the domestic lagoon or mechanical treatment plant exceeds agricultural rates under Section G and/or I, a landfill permit or solid waste disposal permit must be obtained if the permittee chooses to seek authorization for on-site sludge disposal under the Missouri Solid Waste Management Law and regulations per 10 CSR 80, and the permittee must comply with the surface disposal requirements under 40 CFR Part 503, Subpart C.

**SECTION J – MONITORING FREQUENCY**

1. At a minimum, biosolids or sludge shall be tested for volume and percent total solids on a frequency that will accurately represent sludge quantities produced and disposed. Please see the table below.

**TABLE 5**

Biosolids or Sludge produced and disposed (Dry Tons per Year)	Monitoring Frequency (See Notes 1, and 2)		
	Metals, Pathogens and Vectors, Total Phosphorus, Total Potassium	Nitrogen TKN, Nitrogen PAN <sup>1</sup>	Priority Pollutants <sup>2</sup>
319 or less	1/year	1 per month	1/year
320 to 1650	4/year	1 per month	1/year
1651 to 16,500	6/year	1 per month	1/year
16,501+	12/year	1 per month	1/year

<sup>1</sup>Calculate plant available nitrogen (PAN) when either of the following occurs: 1) when biosolids are greater than 50,000 mg/kg TN; or 2) when biosolids are land applied at an application rate greater than two dry tons per acre per year.

<sup>2</sup> Priority pollutants (40 CFR 122.21, Appendix D, Tables II and III) are required only for permit holders that must have a pre-treatment program. Monitoring requirements may be modified and incorporated into the operating permit by the Department on a case-by-case basis.

Note 1: Total solids: A grab sample of sludge shall be tested one per day during land application periods for percent total solids. This data shall be used to calculate the dry tons of sludge applied per acre.

Note 2: Table 5 is not applicable for incineration and permit holders that landfill their sludge.

- 2. Permittees that operate wastewater treatment lagoons, peak flow equalization basins, combined sewer overflow basins or biosolids or sludge lagoons that are cleaned out once a year or less, may choose to sample only when the biosolids or sludge is removed or the lagoon is closed. Test one composite sample for each 319 dry tons of biosolids or sludge removed from the lagoon during the reporting year or during lagoon closure. Composite sample must represent various areas at one-foot depth.
- 3. Additional testing may be required in the special conditions or other sections of the permit.
- 4. Biosolids and sludge monitoring shall be conducted in accordance with federal regulation 40 CFR § 503.8, Sampling and analysis.

**SECTION K – RECORD KEEPING AND REPORTING REQUIREMENTS**

- 1. The permittee shall maintain records on file at the facility for at least five years for the items listed in Standard Conditions PART III and any additional items in the Special Conditions section of this permit. This shall include dates when the biosolids or sludge facility is checked for proper operation, records of maintenance and repairs and other relevant information.
- 2. Reporting period
  - a. By February 19<sup>th</sup> of each year, applicable facilities shall submit an annual report for the previous calendar year period for all mechanical wastewater treatment facilities, sludge lagoons, and biosolids or sludge disposal facilities.
  - b. Permittees with wastewater treatment lagoons shall submit the above annual report only when biosolids or sludge are removed from the lagoon during the report period or when the lagoon is closed.
- 3. Report Form. The annual report shall be prepared on report forms provided by the Department or equivalent forms approved by the Department.
- 4. Reports shall be submitted as follows:  
Major facilities, which are those serving 10,000 persons or more or with a design flow equal to or greater than 1 million gallons per day or that are required to have an approved pretreatment program, shall report to both the Department and EPA if the facility land applied, disposed of biosolids by surface disposal, or operated a sewage sludge incinerator. All other facilities shall maintain their biosolids or sludge records and keep them available to Department personnel upon request. State reports shall be submitted to the address listed as follows:

DNR regional or other applicable office listed in the permit (see cover letter of permit)

ATTN: Sludge Coordinator

Reports to EPA must be electronically submitted online via the Central Data Exchange at: <https://cdx.epa.gov/>. Additional information is available at: <https://www.epa.gov/biosolids/compliance-and-annual-biosolids-reporting>.

5. Annual report contents. The annual report shall include the following:
  - a. Biosolids and sludge testing performed. If testing was conducted at a greater frequency than what is required by the permit, all test results must be included in the report.
  - b. Biosolids or sludge quantity shall be reported as dry tons for the quantity produced and/or disposed.
  - c. Gallons and % solids data used to calculate the dry ton amounts.
  - d. Description of any unusual operating conditions.
  - e. Final disposal method, dates, and location, and person responsible for hauling and disposal.
    - i. This must include the name and address for the hauler and sludge facility. If hauled to a municipal wastewater treatment facility, sanitary landfill, or other approved treatment facility, give the name of that facility.
    - ii. Include a description of the type of hauling equipment used and the capacity in tons, gallons, or cubic feet.
  - f. Contract Hauler Activities:

If using a contract hauler, provide a copy of a signed contract from the contractor. Permittee shall require the contractor to supply information required under this permit for which the contractor is responsible. The permittee shall submit a signed statement from the contractor that he has complied with the standards contained in this permit, unless the contract hauler has a separate biosolids or sludge use permit.
  - g. Land Application Sites:
    - i. Report the location of each application site, the annual and cumulative dry tons/acre for each site, and the landowners name and address. The location for each spreading site shall be given as a legal description for nearest ¼, ¼, Section, Township, Range, and county, or UTM coordinates. The facility shall report PAN when either of the following occurs: 1) When biosolids are greater than 50,000 mg/kg TN; or 2) when biosolids are land applied at an application rate greater than two dry tons per acre per year.
    - ii. If the “Low Metals” criteria are exceeded, report the annual and cumulative pollutant loading rates in pounds per acre for each applicable pollutant, and report the percent of cumulative pollutant loading which has been reached at each site.
    - iii. Report the method used for compliance with pathogen and vector attraction requirements.
    - iv. Report soil test results for pH and phosphorus. If no soil was tested during the year, report the last date when tested and the results.